

Wireless World

ELECTRONICS, RADIO, TELEVISION

SEPTEMBER 1964

F. L. DEVEREUX, B.Sc.

Assistant Editor:
H. W. BARNARD

Editorial:
D. C. ROLFE

Drawing Office:
H. J. COOKE

Production:
D. R. BRAY

Advertisements:
G. BENTON ROWELL
(Manager)
J. R. EYTON-JONES

VOLUME 70 No. 9
PRICE: 2s 6d.

FIFTY-FOURTH YEAR
OF PUBLICATION

423	Editorial Comment	
424	Logarithmic Aerial for Bands IV and V—1	By M. F. Radford
427	Remote Display Unit	By B. W. Hicks
428	Microwave Techniques—2	By K. E. Hancock
432	S.B.A.C. List of Exhibitors	
433	Practical Transistor Circuit Design—1	By G. P. Hobbs
438	Television and Radio Show Guide	
447	Ici on parle le Doubletalk	By "Vector"
448	H.F. Predictions—September	
449	World of Wireless	
451	Personalities	
453	Transistor Audio-frequency Phasemeter	By F. Butler
459	Commercial Literature	
460	Letters to the Editor	
463	Elements of Transistor Pulse Circuits—8	By T. D. Towers
471	Manufacturers' Products	
476	News from Industry	

Managing Director: W. E. Miller, M.A., M.I.E.R.E.
 Iliffe Electrical Publications Ltd., Dorset House, Stamford Street,
 London, S.E.1
 Please address to Editor, Advertisement Manager or Publisher as appropriate

© Iliffe Electrical Publications Ltd., 1964. Permission in writing from the Editor must first be obtained before letterpress or illustrations are reproduced from this journal. Brief abstracts or comments are allowed provided acknowledgement to the journal is given.

PUBLISHED MONTHLY (4th Monday of preceding month). Telephone: Waterloo 3333 (70 lines). Telegrams: "Ethaworld London Telex." Cables: "Ethaworld, London, S.E.1." Annual Subscriptions: Home £2 0s 0d, Overseas £2 5s 0d. Canada and U.S.A. \$6.50. Second-class mail privileges authorised at New York N.Y. BRANCH OFFICES: BIRMINGHAM: King Edward House, New Street, 2. Telephone: Midland 7191. BRISTOL: 11, Marsh Street, 1. Telephone: Bristol 21491/2. COVENTRY: E-10, Corporation Street. Telephone: Coventry 25210. GLASGOW: 123, Hope Street, C.2 Telephone: Central 1265-6. MANCHESTER: 260, Deansgate, 3. Telephone: Blackfriars 4412. NEW YORK OFFICE U.S.A.: 111, Broadway, 6. Telephone: Digby 9 197.

What to look for in the good sets besides the Mullard Picture Tube

The outward sign of a good set is the Mullard picture tube. What goes on behind the scenes is not so obvious but every bit as important. Typical of the contributions which Mullard make to the design of the modern TV receiver are the special valves designed for u.h.f. tuners.

for picture quality

Mullard

scores all along the line



In dual-standard receivers, a separate u.h.f. tuner is required for BBC-2. Why is this so? Why cannot the v.h.f. tuner be adapted for u.h.f.? And why must a u.h.f. tuner have thick steel cover plates and partitions, and continuous rather than turret tuning?

BBC-2 is transmitted at present in channel 33, and provision is made for the eventual utilisation of 44 u.h.f. channels. Accommodation of so many new channels on a turret tuner would be completely impracticable. Continuously variable tuning is therefore essential.

Oscillator radiation from the u.h.f. tuner is subject to stringent international control. Consequently, the unit must be housed in an earthed metal case, and the oscillator must be isolated from the aerial by means of an r.f. amplifier. Stray capacitances and inductances cause heavy signal losses and instability at u.h.f. All interconnecting leads must therefore be as short as possible, and the stages separated by steel partitions.

The care needed in the design of u.h.f. tuners is reflected in u.h.f. valves. In the Mullard PC86 and PC88—the valves employed in almost every current u.h.f. tuner—interelectrode capacitances are minimised by carefully screened pin-to-electrode connections and by specially constructed electrodes, and inductances are reduced by multiple connections between the electrodes and base pins.

MEMBER **BVA** MULLARD LIMITED · MULLARD HOUSE
TORRINGTON PLACE · LONDON W.C.1

12W W-098 FOR FURTHER DETAILS.

Wireless World

VOL 70

NO 9

SEPTEMBER 1964

Return to Earls Court

AFTER what is now generally regarded as the abortive experiment last year, of doing without a National Radio Show, we are back once again in the familiar surroundings of Earls Court.

This journal has sometimes deplored the multiplicity of shows but has never underrated their value as focal points for acquiring and exchanging information, for testing and forming public opinion—even for selling sets!

The dealers will once again be making this the occasion for a visit to London and we do not grudge them the V.I.P. treatment which, in these difficult times, helps to restore confidence and to make them feel wanted by the manufacturers as well as by the customers in their neighbourhood. Not only have the organizers allocated a considerable proportion of the opening time (and of potential box office revenue) for their convenience but the B.B.C. is making a special effort to provide on-the-spot answers to dealers' questions about its service, present and future.

The I.T.A. will also devote a large part of its stand to advance information on specific future programmes and let us not forget that it is the quality of the programme material, from whatever source or on whichever channel, that will decide the future of the domestic radio industry, irrespective of whether it comes to us on 405 or 625 lines or through one loud-speaker or two.

That is not to say that technical advances are unimportant. Although the main problem of dual standard reception was solved well in advance of the start of 625-line transmission we shall expect to see many detail refinements and a general improvement not only in sensitivity but, more important, in signal/noise ratio on Bands IV and V. Aerial designs, too, will show more than their usual range of variations in pursuit of the main theme of higher gain and directivity. If the 19- and 23-inch television sets look from the outside very much like the mixture as before, there will be some interesting miniature portables to catch the public eye, as they never fail to do. And there will be sound receivers and radio-gramophones to which many people are again returning with renewed interest in the sustained quality of the faithful B.B.C. sound service and in a permanent reserve of good disc recordings. Our preview elsewhere in this issue will show where most of the highlights are to be found, but there will also be the usual last-minute surprises and these, together with a first-hand assessment of technical trends, will be dealt with in our next issue.

The decision of the organizers not to demonstrate colour television this year is, we think, a wise one. The B.B.C. has already proved that it can transmit colour on any of the rival systems, and industry has given demonstrations to delegates of the European Broadcasting Union of its prototype receivers; but until a decision on European standards is reached, or until it is quite certain that it cannot be reached, it would be misleading the public to imply, as was done two years ago, that it is just round the corner.

To our foreign visitors we extend a special welcome and the assurance that British manufacturers are this year taking their requirements very seriously. They will find much to interest them in the special demonstration rooms of our set manufacturers and we think that they will already know how to avoid the pitfalls indicated by our contributor "Vector" on another page. He gives several useful pointers but we would not like to say that his sense of direction is always infallible.

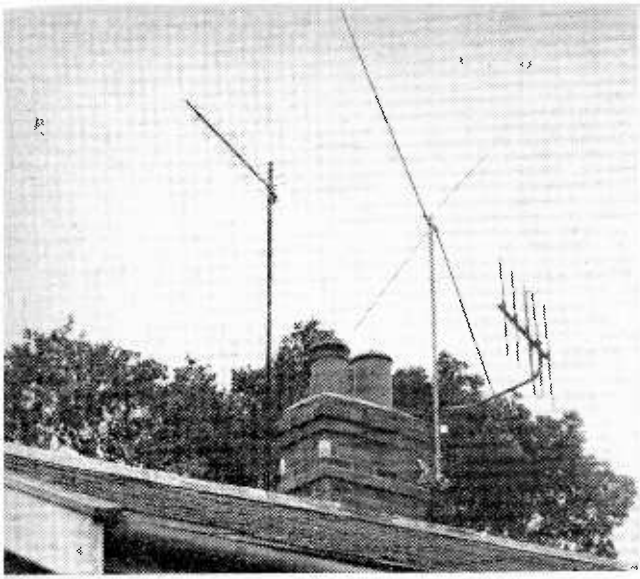

1.—HOW LOGARITHMIC DIPOLE AERIALS WORK

By M. F. RADFORD,* M.A.

Logarithmic Aerial for Bands IV and V

THE recent opening of Bands IV and V has created a need for really wideband television aerials.

Conventional Yagi arrays have been developed to cover the 88 Mc/s bandwidth of the four spaced channels allocated to a single service area. However, for those who require a wider frequency coverage a radically new design is necessary. There are enthusiasts living on the borders of two or more service areas who wish to rotate their aerials to obtain a wider choice of programme. There are merchant seamen and fishermen in coastal waters, caravan dwellers and holidaymakers with portable receivers. For them the only satisfactory solution is a single aerial covering the whole of both bands. Fortunately a suitable design already exists, and it is known as the logarithmic aerial.

How A Simple Dipole Works:—Before attempting to explain the operation of a logarithmic aerial it may be helpful to consider how a simple dipole works.

When a current flows in a wire, an electromagnetic field is produced. The field does not arise instantaneously throughout space, but spreads outwards from the wire at the speed of light. If the current in the wire is now reversed, an opposite field is produced, and this also spreads outwards. The original field, unaware of events since it left the wire, continues to flow outwards to infinity. An alternating current in the wire thus produces an alternating field which spreads in expanding circles like ripples when a stone is thrown into a pond.

The distance between successive oscillations is known as the wavelength, and it is the distance travelled during one cycle of the alternating current. This gives us the well-known fundamental relationship between frequency f , wavelength λ and the velocity v of electromagnetic waves:—

$$v = \lambda f$$

The field flowing outwards represents energy

leaving the wire, energy supplied by the current. Let us see how this transfer of energy takes place. The field produces a voltage in the wire which opposes the current flow, rather like the familiar back e.m.f. in a motor or transformer. It is in doing work against this voltage that the current loses energy to the radiating field. Since the back voltage is proportional to the current it may be regarded as equivalent to that produced by a resistance. This is termed the radiation resistance of the aerial.

In a receiving aerial the above process is reversed. Waves arriving from a distant transmitter excite alternating voltages in the wire. Current flows into the receiver, and the current flowing in the wire sets up a field which cancels out the original field beyond the aerial. In this way part of the incident field is extinguished and its energy is transferred to the receiver. This cancellation is most effective when the receiver has the correct impedance as seen by

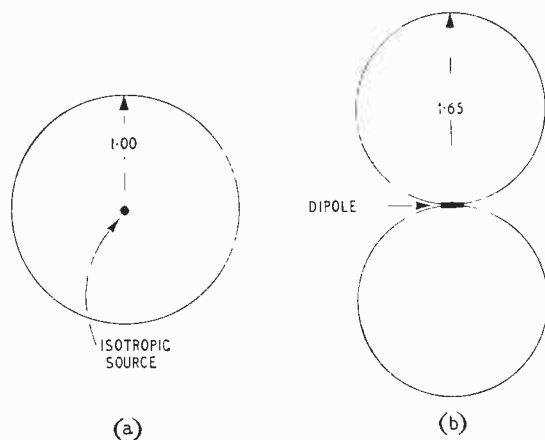

Fig. 1. Sections through field strength polar diagrams of (a) hypothetical isotropic source and (b) half wave dipole on same scale.

*The Marconi Research Laboratories, Chelmsford, Essex.

the aerial, and this optimum impedance is the same as the radiation resistance when the aerial is transmitting.

By now we may have begun to suspect that the requirements for a good transmitter and for a good receiver aerial are the same. There is in fact a law called the law of reciprocity which tells us that the gain of an aerial is the same in either condition, provided that it contains no non-reciprocal components such as amplifiers or ferrite circulators. This law is useful because it is often easier to design a receiving aerial by first considering its operation as a transmitter.

As well as radiation resistance, a wire aerial has both a self inductance L and a self capacity C . In order to keep the aerial impedance a pure resistance, these reactances must be designed to resonate at the operating frequency. A thin wire resonates when its length is a multiple of half a wavelength, and so a half-wave dipole is the simplest resonant aerial. During one cycle, the current travels one wavelength, which is just the distance from one end to the other and back again. In actual fact electrons are oscillating to and fro in the dipole, and the local charge displacement is the difference between the forward and reverse currents.

Neglecting ohmic resistance which is relatively small at u.h.f. the resonance of the aerial is damped by its radiation resistance R and the resistance of whatever is connected to its terminals. It may thus be considered to have a Q like any other tuned circuit. For maximum bandwidth Q must be as small as possible and we need to have the minimum L/C ratio and the maximum radiation resistance. We can reduce L/C by fattening the dipole, but unfortunately this also reduces R , so that there is a limit to the bandwidth of a simple dipole.

The gain of an aerial is measured by comparing its transmitted field intensity with that of an isotropic source. An isotropic source is an imaginary point aerial which transmits equally in all directions. Beloved by theoreticians but quite impossible to construct, its radiation pattern is a sphere and its gain unity or 0 dB. A dipole transmits a solid figure-of-eight radiation pattern. Since no power is available along the axis its gain at right angles to the axis is greater than that of an isotropic source, the actual value being 1.65 or 2.15 dB. This is not nearly enough for most television receiving sites, and so we must seek for ways of concentrating the radiation diagram into a narrower beam in order to improve the gain.¹

How the Yagi Aerial Works:—If we place a second dipole near a resonant transmitting dipole, a voltage is induced in it by the incident field. If the second dipole is unbroken by any feeder connection, a current will flow in it and the received energy will be re-radiated. The phase of the current will depend upon the distance between the dipoles and also upon the reactance of the second dipole. By varying its length the phase of the current, and therefore the phase of the re-radiated field may be made to lead or lag the phase of the incident field. If the dipoles are about a quarter wavelength apart the voltage in the second is nearly half a cycle behind the current in the first, as the waves do not all follow the shortest route between the two dipoles. If the second dipole is short and therefore capacitive, its current leads the induced voltage and so is only about a

quarter cycle later than that in the first dipole. The resulting fields reinforce in the direction of the second dipole and cancel in the opposite direction, so that the second dipole acts as a director.

If the second dipole is too long it is inductive and the current lags the induced voltage so as to be three quarters of a cycle later than the current in the first dipole. For a continuous alternating current this is the same as being a quarter cycle early, the fields thus cancel in the direction of the second dipole and add in the opposite direction. The second dipole now acts as a reflector.

In either case the second dipole increases the gain by a useful amount. Larger increases are obtained by using several directors and two or more reflectors, or possibly a reflecting screen of wire mesh. The latter is placed about a quarter wavelength behind the dipole and produces an image in the same way as a mirror. A half-wave phase change occurs at the

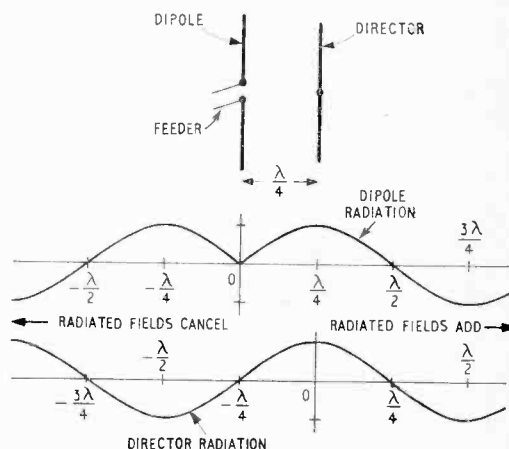

Fig. 2. The director current lags behind the dipole current by a quarter of a cycle. The radiated fields thus add in the forward direction and cancel in the backward direction.

reflecting surface and the waves reinforce in the direction away from the reflector.

This is, of course, a simplified account of how a practical Yagi works. The interactions between the dipoles are more complicated since each one is in the fields of all the others. The radiation resistance of the driven dipole is lowered by these interactions and the dipole is usually folded to restore its impedance to a convenient value. The design of wideband Yagis is a difficult art, and the models now available represent a considerable engineering achievement.² No substantial further increase in bandwidth can be expected from these aerials.

Frequency-independent Aerials:—In March, 1957, Prof. V. H. Rumsey³ and Dr. R. H. DuHamel⁴ announced the discovery of a new class of aerials which could be designed for any bandwidth. In principle these aerials are all based on cones, spirals, or structures that repeat in geometric progression. Each aerial is always fed at the vertex, which is sufficiently small compared with a wavelength that it does not radiate any energy. Currents flow outwards until they reach a part where the dimensions of the repeated structure in terms of wavelengths are such that resonance can occur. Here the currents

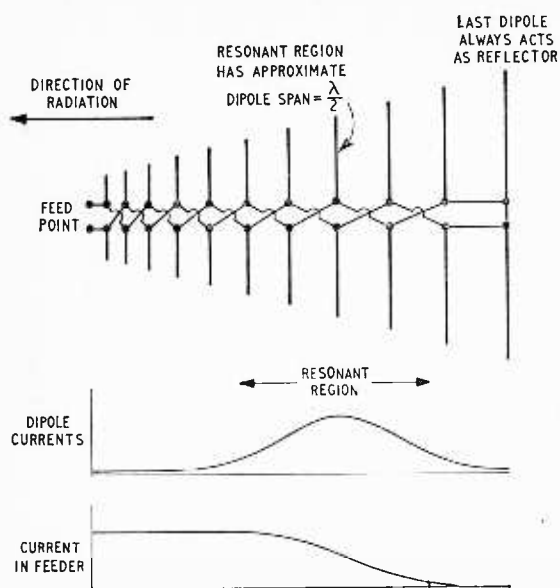

Fig. 3. Schematic diagram of logarithmic dipole aerial. When frequency is changed resonant region moves along array.

build up to maximum and radiation takes place. Beyond the resonance no energy remains in the aerial so that the overall size does not matter. Changing the frequency merely moves the resonant region about on the structure but does not affect the radiation pattern or the impedance. Bandwidth is limited only by the largest and smallest dimensions of the aerial. The first frequency-independent aerials had rather low gains and poor radiation patterns, but performances improved steadily as the operation of the aerials became better understood.

The last step came in June, 1959, with the discovery of the logarithmic dipole aerial on both sides of the Atlantic at about the same time. "This device combines the advantages of the early frequency independent aerials with those of the Yagi. It consists of an array of dipoles having lengths and spacings which increase in geometric progression. All the dipoles are fed from a common balanced twin transmission line. Each dipole has shorter dipoles on one side and longer dipoles on the other, and so behaves like a Yagi aerial in its own right. However, at any one frequency several of these dipoles are near enough resonance to radiate. It is necessary to make sure that the radiated energy from all the active dipoles is combined in phase in the desired direction of radiation. This is done by crossing the twin line between the dipoles. Each dipole, having longer dipoles on one side and shorter dipoles on the other, thinks of itself as part of a Yagi, and so radiates towards the vertex of the array, which is opposite to the direction in which energy is flowing in the line. The dipoles are spaced rather less than a quarter wave apart at resonance so that the phase difference between adjacent dipoles is made up of a quarter wave in the feeder, a half wave due to the reversal of the line, and a further quarter wave path back along the array in space. This totals one wavelength and the dipoles therefore reinforce each other in radiating towards the vertex end. In the opposite direction, i.e. towards the larger end, the radiation is

very weak. Not only are the dipoles unwilling to radiate in that direction because of the longer dipoles behind them but the crossing of the feeder ensures that waves from adjacent dipoles cancel out in this direction. In practice the radiation from the back of the aerial is around 30 dB down, or about one thousandth of the power in the forward radiation. This is 10 dB better than an average Yagi achieves, and thus the logarithmic aerial is particularly useful for rejecting unwanted signals, interference, and "ghosts."

The above explanation should be adequate for most practical purposes, although it clearly fails to answer several difficult questions. For those who wish to dig deeper a full mathematical solution of the aerial was published in 1961 by Dr. R. L. Carrel. This article derives from basic theory the optimum dimensions of the aerial for any given size and frequency range. Its recommendations agree remarkably well with the designs produced two years earlier by cut-and-try empirical methods.

The second part of this article will describe a logarithmic dipole aerial for Bands IV and V suitable for use on reasonably good sites. It remains to add a word of warning. On sites where the field strength is low logarithmic aerials are inferior to Yagis of the same overall size, since only a fraction of their dipoles are active at any one frequency while all the dipoles of the Yagis are pulling their full weight. However, on good sites or for mobile use, the logarithmic aerial can provide a choice of programme that no other aerial can offer.

REFERENCES

1. For a more rigorous explanation see "Antennas" by J. Kraus, McGraw Hill 1950. Chapter 2.
2. Robb, A. C. "U.H.F. Television Reception." *Wireless World*. Vol. 69 No. 8. August, 1963, p.385.
3. V. H. Rumsey. "Frequency Independent Antennas." I.R.E. National Convention Record. March, 1957, part I, p. 114.
4. R. H. DuHamel, D. E. Isbell. "Broadband Logarithmically Periodic Antenna Structures." I.R.E. National Convention Record. March, 1957, part I, p. 119.
5. The Marconi Company Ltd. British Patent No. 884,889. 8th Jun, 1959.
6. D. E. Isbell. "Log-Periodic Dipole Arrays." Illinois University Antenna Laboratory Technical Report No. 39. 10th June, 1959.
7. R. L. Carrel. "The Design of Log-Periodic Dipole Antennas." I.R.E. International Convention Record, March, 1961. Part I, p. 61.

INFORMATION SERVICE FOR PROFESSIONAL READERS

To expedite requests for further information on products appearing in the editorial and advertisement pages of *Wireless World* each month, a sheet of reader service cards is included in this issue. The cards will be found between advertisement pages 16 and 19.

We invite readers to make use of these cards for all inquiries dealing with specific products. Many editorial items and all advertisements are coded with a number, prefixed by I2 WW, and it is then necessary only to enter the number(s) on the card.

Readers will appreciate the advantage of being able to fold out the sheet of cards, enabling them to make entries while studying the editorial and advertisement pages.

Postage is free in the U.K., but cards must be stamped if posted overseas. This service will enable professional readers to obtain the additional information they require quickly and easily.

REMOTE DISPLAY UNIT

By B. W. HICKS*

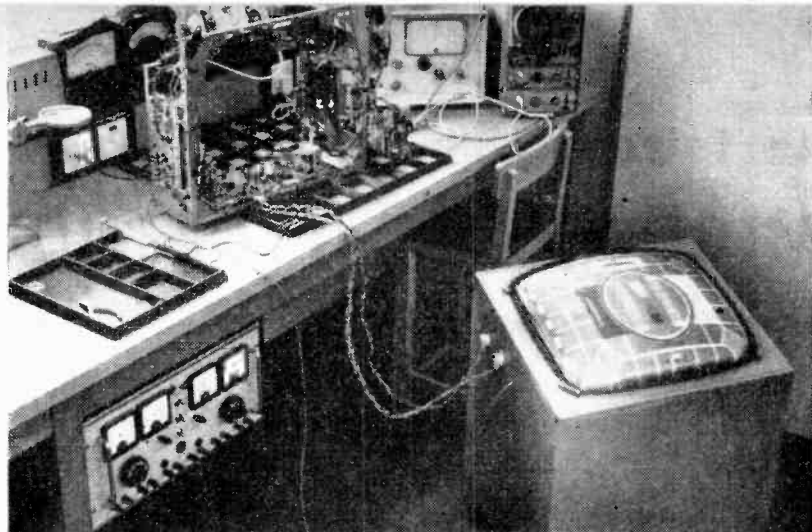

The display unit in use at the Southgate Technical College.

OPERATION OF A TELEVISION TUBE AT A DISTANCE FROM THE CHASSIS

THE proper training of television service engineers demands a reasoned approach and a gradual increase in the complexity of the fault or faults that the engineer has to find and cure. Even with the best of modern television receivers there is considerable difficulty in making all components readily accessible, and the presence of the tube makes this still more of a problem. It is therefore desirable, particularly when the training is in its early stages, for the tube to be removed so that not only are all components easily found, but the connection of oscilloscopes, valve voltmeters, and even the humble multi-range meter is a simple matter. It is, however, necessary to maintain a picture on the tube so that the process of fault identification, using the tube itself as a reference, can be maintained.

The connections to scan coils and all tube electrodes except the cathode can be extended to a

length of 6 to 8 feet without undue effects, but to use anything like this for the cathode results in severe loss of definition. An ordinary conventional cathode follower gives some improvement, but the result is still unsatisfactory because of its limitations in transient response and output impedance.

A White cathode follower[†] was therefore tried and a modified circuit evolved as shown in Fig. 1. No coupling capacitors were employed, and the values chosen provided an advantage in gain-bandwidth of a factor of 4 compared with the normal cathode follower. The higher the g_m of the triodes employed the lower was the output impedance and the faster the transient response. It was possible to use a multi-core cable 9ft long between the receiver and the tube and still resolve the 3 Mc/s bars on test card C. With pentodes the length of lead could be extended to 15ft. It was found preferable to employ one multi-core cable for the scan coils and e.h.t. and a second for the tube connections, but in no case was the cathode wire separated.

In 9 months of almost daily use no trouble whatever has been experienced. The PCC 84 or PCC 89 employed has been wired permanently to the receiver, its heater being placed next to the c.r.t. in the heater chain. The receiver shown in the photograph is a Ferguson 705T, and with this receiver only minor adjustments were needed to the line linearity controls to compensate for extra lead capacitance.

REFERENCES

"Transient Analysis of the White Cathode Follower," Melvin Brown. *Review of Scientific Instruments* April, 1960, pages 403 to 409.

"Stacked Valve Circuits," J. B. Earnshaw, *Electronic and Radio Engineer*, November, 1957, pages 404 to 410.

"Multistage Amplifier Output Impedance," J. B. Earnshaw, *Electronic Engineering* 1954, Vol. 26, pages 553 to 557.

Radio Designers Handbook (F. Langford-Smith) 1952 also gives 32 references.

* Southgate Technical College.

† The White cathode follower was first patented in 1944 by Eric L. C. White under U.S. Patent No. 2358428.

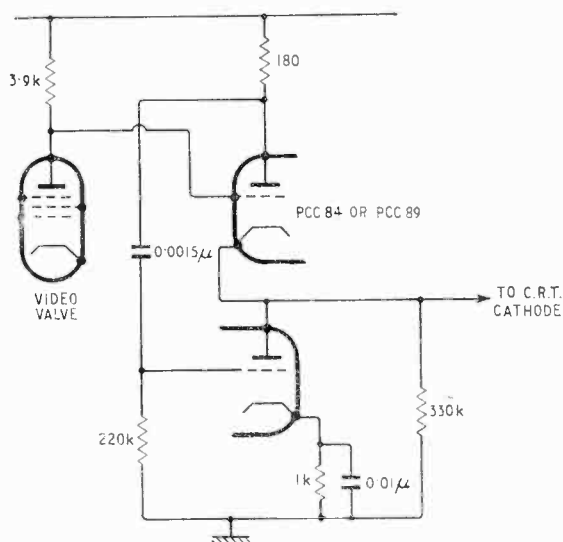

Fig. 1. White cathode follower circuit for c.r.t. drive.

An Introduction to MICROWAVE TECHNIQUES

2.—MICROWAVE THEORY

By K. E. HANCOCK*

IN the previous article covering the history and present applications of microwave techniques it was mentioned that most microwave circuits use hollow tubes called waveguides as the transmission line, instead of the conventional wires or coaxial cable. Let us now see how this is possible. Most microwave theory is expounded in terms of the electromagnetic field in a circuit, as the usual voltage and current parameters have little meaning, as will be shown later.

Propagation of Waves in a Waveguide

Electromagnetic Waves:—From basic a.c. theory we know that a radiating conductor will produce a

E and H fields. This is shown diagrammatically in Fig. 1.

Waves in Free Space:—If we extend the fields shown in Fig. 1, immediately we get the pattern of an electromagnetic wave in free space, where the curvature of the magnetic field is small enough to be ignored. As the field alternates the direction of both E and H fields will reverse every half cycle, the direction of propagation remaining constant, as shown in Fig. 2.

Propagation in a Waveguide:—If we wish to constrain an electromagnetic wave so that it is propagated in an enclosed path such as a tube or waveguide, without significant attenuation, it must be arranged to comply with certain laws propounded by Maxwell. These state among other things, that for an electromagnetic wave to propagate along a plane surface the electric field must be at right angles to, or zero at that surface. Let us now consider two waves, each like that shown in Fig. 2 crossing each other at an angle to produce the field pattern as shown in Fig. 3. At all points along lines A the electric field cancels and we have the conditions (zero field) for the Maxwell equations. We can, therefore, put plane surfaces at any of the lines A and the wave will propagate in the direction shown in Fig. 3.

If we enclose the other two sides the equations will again be met as the E field will cut them at right angles. It will be seen then that a wave can be directed down a rectangular tube provided that the sides A are correctly spaced. Let us consider the limits of positioning the sides with regard to the wavelength of the signal we wish to propagate. It will be seen from Fig. 3 that the two waves that make up the pattern may cross at any angle between zero and 90°, but in all cases the guide wavelength (λ_g) is always greater than the free-space wavelength (λ_0).

Referring again to Fig. 3, it can be shown from simple geometry that

$$\left(\frac{1}{\lambda_g}\right)^2 = \left(\frac{1}{\lambda_0}\right)^2 - \left(\frac{1}{2a}\right)^2$$

transposing this gives us

$$\lambda_g = \frac{\lambda_0}{\sqrt{1 - \left(\frac{\lambda_0}{2a}\right)^2}}$$

Examining this equation it will be seen that as the

* Canadian Marconi Company

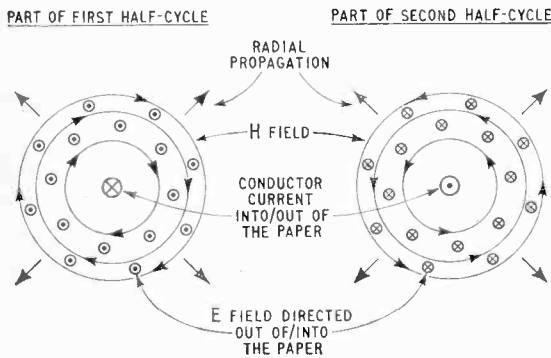

Fig. 1. Fields around a radiating conductor.

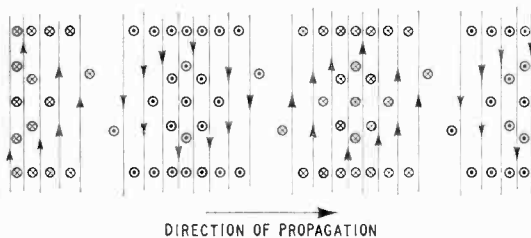
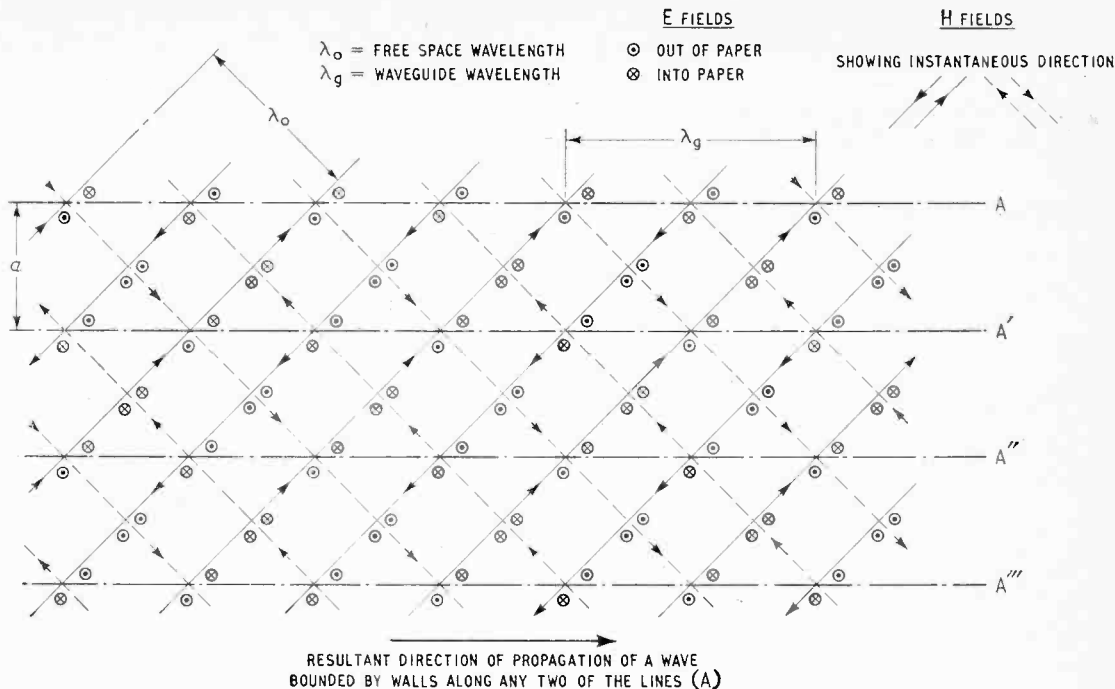

Fig. 2. Electromagnetic fields in free space remote from the source.

magnetic field (H) concentric with the conductor, and an electric field (E) parallel to the conductor, such that the two fields always intersect at right angles. The direction of propagation is given by the right hand rule and will be mutually perpendicular to the



free-space wavelength (λ_o) tends towards $2a$ the expression $\sqrt{1 - \left(\frac{\lambda_o}{2a}\right)^2}$ tends towards zero and

the guide wavelength (λ_g) tends towards infinity, at which point propagation ceases. Our limit for propagation therefore is when the free-space wavelength (λ_o) is equal to twice the width of the waveguide. This limiting wavelength is called the cut-off wavelength (λ_c).

It will be seen from this that any waveguide acts as a high-pass filter allowing all wavelengths shorter than $\lambda_c = 2a$ to pass but rejecting those longer than this.

Modes:—Referring again to Fig. 3 we can place our broad or “ a ” dimension of the guide on any two of the A lines. Considering two adjacent lines we will obtain field patterns as shown in Fig. 4. This is called the “ H_{10} (magnetic)” or “ TE_{10} (transverse electric)” mode, meaning that the variation of electric field is across the guide, with no longitudinal component, the (1) denoting that there is one maximum across the broad dimension and the (0) denoting that there is no maximum across the narrow dimension.

We have already seen that for a particular “ a ” dimension there is a lower frequency limit. If, however, the frequency is increased λ_o will decrease until it is possible to accommodate two sets of zero E lines, i.e. A to A' in Fig. 3, between the waveguide walls. This mode is termed H_{20} following the same reasoning as above. It will readily be seen that given correct dimensions with relation to frequency modes of any suffix can be propagated. This, however, causes great difficulty of measurement and manipulation, so various waveguide sizes are used for given bands of frequencies so that only the TE_{10} mode is propagated (thus setting the upper

Above: Fig. 3. Plane surfaces inserted at positions A in a free field simulate the action of a waveguide.

Below: Fig. 4. Electromagnetic wave patterns in a waveguide TE_{10} mode.

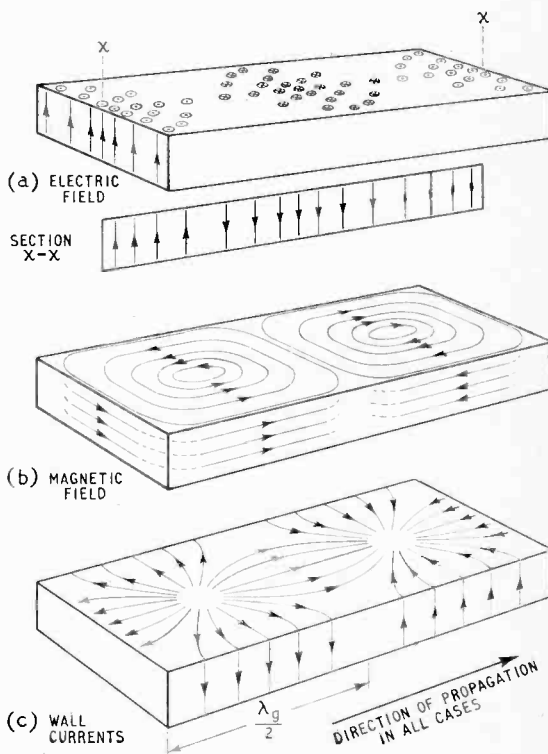

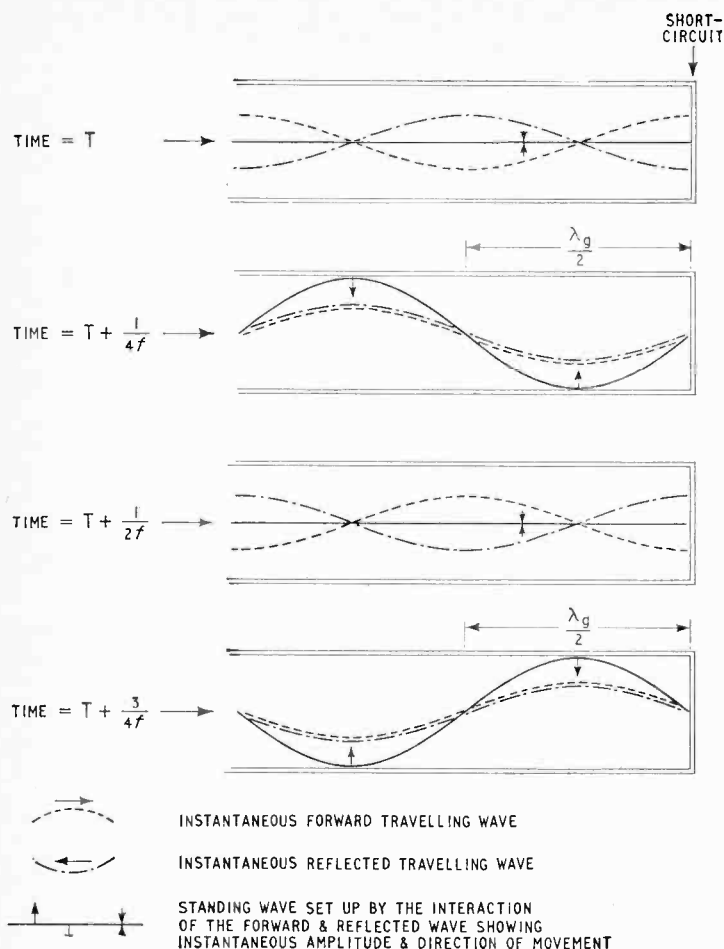

Fig. 5. Effect of reflections in a waveguide.

limit of frequency for a given waveguide size) and the wave is always well above cut-off frequency (thus setting the lower frequency). Unless otherwise stated the TE₁₀ mode only will be considered from this point on. This mode is called the dominant mode. Attenuation in a waveguide is caused mainly by resistive and skin effects and will, for a given size of waveguide, increase as cut-off frequency is neared. Table 1 gives a selection of common guide dimensions and parameters.

Within the limits set by the second suffix of the mode the narrow or "b" dimension of guide is not critical with regard to frequency, and is commonly made about half of the "a" dimension. However, this dimension does set a limit to power handling capacity due to arcing. The guide can, however, be pressurized to increase the dielectric strength and/or blown with hot air within the guide to alleviate this problem.

Waveguide Surface Currents:—
The interaction of the "H" field with the waveguide wall sets up current in the waveguide flowing at right angles to the magnetic field. These are shown in Fig. 4(c). It must be remembered that the patterns are not stationary but progress in the direction of propagation at a speed proportional to the guide wavelength. Wall currents are important from the point of

TABLE I
RIGID RECTANGULAR WAVEGUIDE DATA

WG	Operating Range for TE ₁₀ Mode		Cut-off for TE ₁₀ Mode Frequency (kMc/s)	Power Rating (lowest to highest frequency) (MW)	Attenuation (lowest to highest frequency) (dB/100 ft.)	Material	Dimensions (inches)		
	Frequency (kMc/s)	Wavelength (cm)					Inside	Tol.	Wall Thickness (Nominal)
6	1.12-1.70	26.76-17.63	0.908	11.9-17.2	0.317-0.212 0.269-0.178	Copper Aluminium	6.500-3.250	±0.005	0.080
8	1.70-2.60	17.63-11.53	1.372	5.2-7.5	0.588-0.385 0.501-0.330	Copper Aluminium	4.300-2.150	±0.005	0.080
10	2.60-3.95	11.53-7.59	2.078	2.2-3.2	1.102-0.752 0.940-0.641	Copper Aluminium	2.840-1.340	±0.005	0.080
12	3.95-5.85	7.59-5.12	3.152	1.4-2.0	2.08 - 1.44 1.77 - 1.12	Copper Aluminium	1.872-0.872	±0.005	0.064
14	5.85-8.20	5.12-3.66	4.301	0.56-0.71	2.87 - 2.30 2.45 - 1.94	Copper Aluminium	1.372-0.622	±0.004	0.064
15	7.05-10.00	4.25-2.99	5.259	0.35-0.46	4.12 - 3.21 3.50 - 2.74	Copper Aluminium	1.122-0.497	±0.004	0.064
16	8.20-12.40	3.66-2.42	6.557	0.20-0.29	6.45 - 4.48 5.49 - 3.83	Copper Aluminium	0.900-0.400	±0.003	0.050
18	12.40-18.00	2.42-1.66	9.486	0.12-0.16	9.51 - 8.31 — —	Copper Aluminium	0.622-0.311	±0.0025	0.040
20	18.00-26.50	1.66-1.13	14.047	0.043-0.058	6.14 - 5.36 20.7 - 14.8 17.6 - 12.6 13.3 - 9.5	Copper Aluminium Silver	0.420-0.170	±0.0020	0.040
22	26.50-40.00	1.13-0.75	21.081	0.022-0.031	— — — —	Copper Aluminium	0.280-0.140	±0.0015	0.040
24	40.00-60.00	0.75-0.50	31.357	— —	21.9 - 15.0	Silver	0.188-0.094	±0.0010	0.040

view of loss in a guide, the resistivity and surface finish of the waveguide producing I²R losses, and from the consideration of propagating or radiating from the guide into free space or other medium. As radiation implies a potential difference this only occurs from a waveguide when a break in the guide cuts across the wall current. We can, therefore, make a narrow vertical slot of any height in the narrow side of the guide without radiation. We can also make a very narrow slot of any length down the exact centre of the broad side of the guide without radiation. However, as soon as the slot is moved off centre or is made a significant width radiation will occur. From this it is clear that a curved slot in any position will radiate.

Waveguide Characteristics:—Let us now consider the transmission characteristics of a typical standard waveguide. Waveguide number WG 14, a size in common use in radio link work, has inside dimensions 1.372 inches by 0.622 inches and a recommended frequency range of 5,850 Mc/s to 8,200 Mc/s.

From the "a" dimension of 1.372 inches we can determine the cut-off frequency

$$= 2a = 2 \times 1.372 \times 2.84 \text{ cm} = 6.98 \text{ cm}$$

so the frequency of cut-off

$$f_c = \frac{3 \times 10^{10}}{6.98} \text{ cycles/sec} = 4,290 \text{ Mc/s}$$

It will be noted that the recommended usable frequencies fall between f_c and $2f_c$ with a greater margin on the lower side. This is typical of all standard waveguides. WG 14 is commonly constructed from brass or aluminium by a seamless drawing process in lengths up to 20 feet.

For special applications the waveguide is also made from copper, silver, invar and magnesium. Standard wall thickness is 0.064 inch with a tolerance of ± 0.004 inch. Both of these figures can be varied for special applications. Considering brass waveguide the theoretical attenuation from lowest to highest frequencies in the recommended range is 4.61 to 3.08 dB per 100 feet. In practice, however, due to surface imperfections and tarnishing, losses at least 50% greater than these figures can be expected. It will be noted that whilst attenuation increases as waveguide size decreases, for a given waveguide operating in the dominant mode attenuation decreases as frequency increases.

Reflections and Standing Waves:—If we consider a wave travelling down a guide and meeting a perfect short circuit, as no absorption takes place the wave will be reflected without attenuation and add algebraically with the original incident wave travelling up the guide. As shown in Fig. 5 the result will be a wave fixed in position but varying in amplitude at the frequency of propagation. This is termed a standing wave. If there is 100% reflection and no attenuation the maximum amplitude of the standing wave will be twice that of the incident wave. It will be readily seen that by accurately measuring the distance between two minima by methods to be shown in a later article, we have a convenient and very accurate method of measuring the guide wavelength. If we replace the short circuit with a discontinuity in the guide, say a poor flange connection, we will get a proportion of the incident wave reflected, the amount being proportional to the size, position, and composition of the reflecting surface. This will result in a standing wave of smaller amplitude. If the discontinuity is removed and replaced by a matched termination, a device which absorbs all the power fed to it, no reflection will occur and the amplitude of the standing wave will be zero.

Voltage Standing Wave Ratio:—It can be seen from the foregoing that by measuring the amplitude of the standing wave we get a measurement of the mismatches in the guide causing reflections. This is done in practice by measuring the ratio between the peaks and the troughs of the standing wave as shown

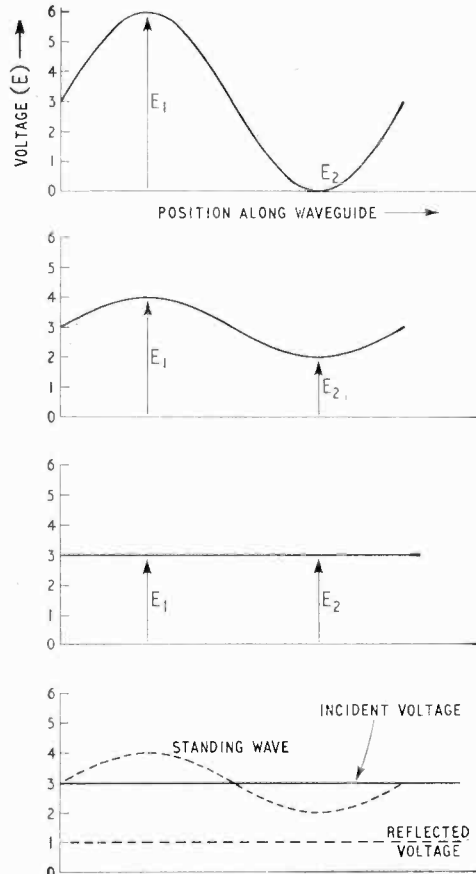

V.S.W.R. FOR COMPLETE REFLECTION

$$= \frac{E_1}{E_2} = \frac{6}{0} = \text{INFINITY}$$

PARTIAL REFLECTION

$$= \frac{E_1}{E_2} = \frac{4}{2} = 2:1$$

NO REFLECTION

$$= \frac{E_1}{E_2} = \frac{3}{3} = 1:1$$

REFLECTION COEFFICIENT (ρ)

$$\rho = \frac{\text{REFLECTED}}{\text{INCIDENT}} = \frac{1}{3} = 0.333$$

$$\text{V.S.W.R.} = \frac{1+\rho}{1-\rho} = \frac{1.333}{0.666} = 2:1$$

Fig. 6. Voltage standing wave ratio and reflection coefficient.

in Fig. 6. This ratio is called the voltage standing wave ratio or v.s.w.r. and is given by E_{max}/E_{min} .

A perfect circuit with no reflections will therefore have a v.s.w.r. of unity, written 1 : 1, and a non-perfect circuit a v.s.w.r. greater than unity. The practical limit on v.s.w.r. measurement set by waveguide tolerances and measuring equipment is around 1.01 : 1. Special equipment and components will bring this down to around 1.002 : 1, but a normal high-quality waveguide run of any length and bandwidth will have a v.s.w.r. of the order of 1.03 : 1, so in general the 1.01 : 1 limit is adequate. The match of normal waveguide components vary between around 1.02 : 1 and 1.5 : 1 depending on the component, bandwidth, frequency etc.

Although the ratio E_{max}/E_{min} for v.s.w.r. is used by the majority of microwave engineers, the inverse is sometimes used giving a figure below unity for a non-perfect match.

Where an uninterrupted signal path is required, any discontinuity or irregularity in the guide will give a v.s.w.r. greater than unity with the following major results—

- (a) An attenuated output due to part of the signal being reflected.
- (b) Reduced power-handling capacity between the obstruction and the power source due to the increased peak amplitude of the standing wave over the incident wave.

- (c) Multiple reflections causing echoes and changes in the phase delay over a range of frequencies.

Reflection Coefficient (ρ):—An alternative method of assessing the reflection is to measure the fraction of the incident wave reflected. This is termed the reflection coefficient (ρ), e.g. if the incident voltage is 6 and the reflected voltage 3 the reflection coefficient is $3/6=1/2$.

The Relationship between V.S.W.R. (S) and Reflection Coefficient (ρ):—Let us now consider what relationship exists between v.s.w.r. (S) and reflection coefficient (ρ).

$$S = \frac{E_{max}}{E_{min}} = 1 \text{ with no reflections}$$

With reflections E_{max} is increased by the fraction of the wave reflected, that is the reflection coefficient, and E_{min} reduced by the same amount.

$$\text{This gives us } S = \frac{1+\rho}{1-\rho}$$

$$\text{and } \rho = \frac{S-1}{S+1}$$

In the case above where $\rho = \frac{1}{2}$

$$S = \frac{1+\frac{1}{2}}{1-\frac{1}{2}} = 3:1$$

[The next instalment in this series will deal with microwave power sources.]

S.B.A.C. EXHIBITORS

RADIO AND ELECTRONICS MANUFACTURERS AT FARNBOROUGH

BOTH in the air and on the ground radio and electronic techniques are increasingly contributing to safety, reliability and punctuality. It is not surprising therefore that electronic and radio equipment will again constitute a major part of the static exhibition at the Farnborough Air Show (7th-13th September). Organized by the Society of British Aerospace Companies (until recently the Society of British Aircraft Constructors) the show will again be held at the Royal Aircraft Establishment, Farnborough, Hants., where, in addition to the static exhibition, there will be the ever-popular flying display.

From the list of some 300 exhibitors we give below those known to be showing items of particular interest to electronics and radio engineers.

A.K. Fans.	Cementation (Muffelite).
Accles & Pollock.	Chloride Batteries.
Aircraft-Marine Products.	Ciba (A.R.L.).
Airtech.	Cole, E. K.
Amphenol-Borg.	Computing Devices of
Amplivox.	Canada.
Associated Electrical	Cossor, A. C.
Industries.	Cossor Electronics.
B.I. Callender's Cables.	Decca Navigator Co.
Bakelite.	Decca Radar.
Belling & Lee.	Dowty Group.
Beme Telecommunications.	Dzus Fastener.
British Communications	E.M.I. Electronics.
Corp.	Ekco Electronics.
Brown, S. G.	Electronic Insulators.
Bryans.	Elliott Group.
Burndept Electronics.	English Electric Group.
Cannon Electric.	

Ferranti Group.	Rank Group.
Formica.	Redifon.
G.E.C. Electronics.	Royston Industries.
G.K.N. Group.	Sangamo Weston.
General Electric Co.	Smart & Brown
General Precision Systems.	(Connectors).
Graseby Instruments.	Smiths Aviation Group.
Hawker Siddeley Aviation.	Solartron Electronic
Hellermann.	Group.
Hendrey Relays.	Southern Instruments.
Honeywell Controls.	Sperry Gyroscope Co.
imhof.	Standard Telephones
International Nickel Co.	Group.
Lucas Rotax Group.	Teddington Aircraft
M.L. Aviation.	Controls.
Marconi Group.	Thermionic Products.
Marconi Instruments.	Thompson, J. Langham.
Microcell.	Thorn Electrical.
Ministry of Aviation.	Tucker Eyelet Co.
Negretti & Zambra.	Ultra Group.
Newmark, Louis.	Vactric Control Equipment.
Plannair.	Venner.
Plessey Group.	Wandleside Warren Wire.
Pritchett & Gold.	Westinghouse Brake &
Pullin & Co.	Signal.
Pye.	Whiteley Electrical.
Pye-Ling.	Wiggin, Henry, & Co.

As already announced we hope to include in our next issue a survey of the trends in aeronautical electronic and radio equipment during the past two years since the last Farnborough Show.

Introduction to Practical Transistor Circuit Design

1.—RELEVANT PARAMETERS AND CIRCUIT IMPEDANCES

By G. P. HOBBS*, B.A., Grad. I.E.E.

SOME people with a practical outlook on life manage their affairs by means of a series of hits and misses, whilst others prefer to depend more on a philosophy. In electronics the two extremes again show themselves, and on the one hand an engineer will prefer methods of trial and experiment whilst on the other the theoretical approach will be advocated. It would be treading on the most dangerous ground to suggest where, for success, the line should be drawn between these extremes and, in fact, in the ensuing discussions on design the subject matter will, it is hoped, suit a wide range of palate. It is felt all the same that a modicum of background knowledge (call it theoretical if you like) is essential and that something additional is needed to supplement that general conception of the transistor as an amplifying device endowed with a current gain.

So to what extent in design work should equivalent circuits feature? There is apparently such a proliferation of transistor equivalent circuits in use that many an engineer is tempted to throw up his books in despair. Maybe this is only an apparent state of affairs. To begin with there seem to be two things involved; one comprises the actual component elements of the equivalent circuits themselves, and the other involves quantities which can be directly measured between the three transistor terminations. Components like $r_{b'e}$, $r_{b'c}$ and r_{ce} shown in Fig. 1 belong to the first category; for the second we may quote items like h_{11} or h_{ie} . The beauty of these latter h-parameters lies in their lack of association with any form of equivalent circuit; they are simply external measurements made on the "black box." Transistor manufacturers are tending to adopt these h-parameters in their specifications and a very laudable policy this is, as measurements can always be made to check them.

h-parameters:—In these symbols, h stands for hybrid in the sense that the symbols represent a mixture of ratios and impedance and admittance values, but in no sense are they intimately connected with the common emitter hybrid- π circuit of Fig. 1. Two forms of notation are in use for h-parameters; one uses the numerals 1 and 2 as subscripts to h and the other letters. The letters give the more obvious indication of the measurement involved, so we shall stick to these. h_i refers to an input impedance and h_o to an output admittance of a transistor in a configuration denoted by the second subscript, e, b or c for common emitter, common base or common collector. In addition h_f refers to the forward current transfer ratio (the current gain) and h_r to the reverse voltage

transfer ratio (the feedback factor, which we will come to). h-parameters quoted in full represent the true complex impedance or admittance presented under the conditions of measurement, but often it is convenient to consider solely the real, that is to say resistive, component. As no mention will be made of selective amplifiers, this article will be confined to describing the low-frequency components of the h-parameters. A case will be made in next month's issue for leaving the high-frequency characteristics of a wide band amplifier to the experimental side of the design.

Equivalent Circuit:—Now that a mention has been made of the h-parameters, we can proceed to examine the internal workings of the "black box" shown in Fig. 1. Although this is the most rewarding of equivalent circuits, it need not be felt that the common base or common collector configurations are being neglected; their particular properties will be worked into the discourse. The common collector stage is more generally known as an emitter follower, having properties similar to that of the cathode follower.

We shall examine the behaviour of the "black box" in various arrangements (input open or short circuit, etc.) so that on being presented with an actual circuit problem, we shall be enabled to analyse the current or voltage gain and loading effects upon inspection. The aim in this article will be two-fold: first to produce all the strictly necessary and easily remembered circuit equations and, second, in finding these relationships, to examine the operation of the "black box" in the light of a few simple transistor actions. In case these should seem formidable objectives, let it be emphasized that only a general guidance is being sought; the absolute magnitudes of the "black box" elements are not of concern. The derivations and method of approach will not be at all rigorous, but should help in providing the necessary familiarity with the hybrid- π network.

So although our insight will be only into a simplified description of the transistor, this will be more

Fig. 1. Common emitter hybrid- π equivalent circuit.

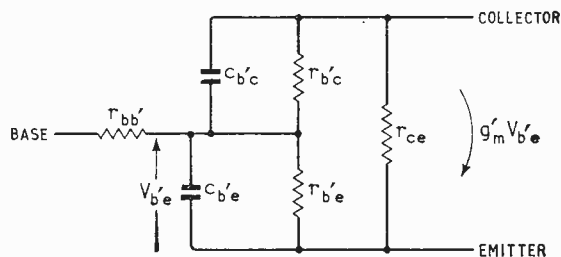

* The Marconi Company Ltd., Chelmsford, Essex.

than sufficient to give the necessary background theory. Indeed, one often recurring simplification in our analysis will, in effect, be to write β where $(\beta + 1)$ should strictly appear. β is the common-emitter current gain and for a particular transistor type may have a production spread over the range of, say, 40 to 120. So in view of this the unity in $(\beta + 1)$ can hardly be held to have any significance. Yet the reader is probably aware of text-book equations littered all over with practical irrelevances like this. The aim in this article will be to make as many useful approximations as may reasonably be justified.

β has just been introduced as our symbol for the small signal current gain in grounded emitter. α' or h_{fe} are alternative descriptions; to use h_{fe} an h-parameter is to be more "with it" these days but β is a symbol easily said and written and is difficult to mistake. Apologies are made if this choice is not in keeping with the reader's own usage. An engineer is entitled to defend his own choice of pet parameters. For β we will take a value of 50 and use it in a standard example to help fix ideas. This example is an n-p-n transistor, drawn in Fig. 2, and is biased to a standing collector current of 4mA.

No comment should be needed to explain why the base current is $80\mu\text{A}$. Leakage current is here neglected; its effects will be dealt with in a following article. The values of β and I_C are chosen for easy mathematics, but otherwise bear no relation to each other. The current gain is nevertheless sensitive to change in collector current, but again this is an effect which will be dealt with in a later issue.

A further independent factor, the mutual conductance, should now be written down. Here we shall define a mutual conductance g'_m which relates to the operative region of the transistor and write:

$$g'_m = 40 I_C \text{ mA/volt} \dots \dots \dots (1)$$

where I_C is in mA

The value of g'_m can be shown from semiconductor physics to be directly related to the collector current (or to the emitter current as the two are very nearly equal) and as such must be invariant from one transistor to the next. It can be less than $40 I_C$ but for design purposes this round figure suffices.

In our example, I_C being 4mA, g'_m is given to sufficient accuracy as 160mA/volt. As with valves, g'_m tends to increase as the operating current goes up and, in fact, goes on increasing proportionally as the collector current I_C is made progressively larger. Due to the interposition of $r_{bb'}$ (Fig. 1) between the functioning base region and the external base lead, the mutual conductance as defined by

$$g_m = \left(\frac{\delta I_C}{\delta V_{BE}} \right) V_{CE}$$

reaches a roughly limiting value of

$$\frac{\beta}{r_{bb'}}$$

at high collector currents. g_m can be directly measured and is the mutual conductance normally referred to by the majority. For the purposes of this article the symbol g'_m has been allotted to the quantity

$\left(\frac{\delta I_C}{\delta V_{b'e}} \right) V_{CE}$, the mutual conductance, so to speak, on the inside of $r_{bb'}$. Equation (1) then retains a general validity and the nuisance value of $r_{bb'}$ may be dealt with separately.

A grounded emitter stage voltage-driven on its base must always produce a distorted current waveform at the collector. The distortion will only be

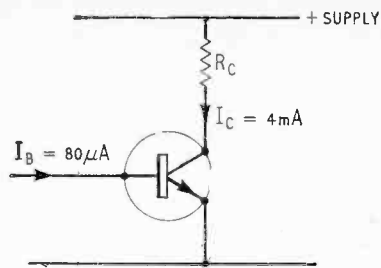

Fig. 2. Standard example—an n-p-n transistor with positive supply rail drawn at the top. (This arrangement should be to everyone's liking.)

kept small where the signal current excursion is a small proportion of the standing current. It will be shown shortly that degeneration by a series emitter feedback resistor will improve the linearity.

All the parameters are dependent to some degree on collector current; even β has a maximum value at some operating current. Nevertheless β varies to a much smaller extent than does g'_m with I_C , and this must be one sound reason for christening the transistor a current-operated device. This certainly does not preclude us from treating it as a valve-like device with rather variable impedances over the operating range.

It seems nonsense to force oneself to begin again at square one in the semiconductor field simply by refusing to draw on past experiences of thermionic designs.

Take for example the cathode impedance of a valve, $\frac{1}{g_m}$; this is also the impedance looking into the

emitter of a transistor. If any further proof is required, consider the I_C versus $V_{b'e}$ characteristics (compare I_a/V_g for constant V_a for a valve); the slope will be g'_m . Under investigation is the effect of a change in base-to-emitter voltage on the collector current or, indeed, on the emitter current as

$$I_B = \left(1 - \frac{1}{\beta} \right) I_C \text{ may justifiably be approximated to } I_B = I_C.$$

So surely the effect of a base-to-emitter voltage change on the current into the emitter gives the emitter resistance r_e . The same argument shows that the base resistance is βr_e because the current into the base is β times smaller; but more of this in a moment; first we may write from expression (1)

$$r_e = \frac{1}{g'_m} = \frac{1}{40 I_C} \text{ k}\Omega \text{ or } \frac{25}{I_C} \Omega \text{ (} I_C \text{ in mA) } \dots \dots (2)$$

In our example of Fig. 2 where $I_C = 4\text{mA}$, r_e is just over 6 ohms. This is the first appearance of a resistance being inversely proportional to the collector current. All the "black box" intrinsic resistances show this dependence for, as we shall learn, they may all be related back to r_e . This situation restores one's faith in the nature of things—even in such abstruse matters as semiconductor physics—for a high current device must surely feature a low impedance and vice versa.

Our next concept, hinted at above, is the one which says that impedances in the emitter circuit, when viewed from the base, appear β times greater in

(Continued on page 435)

magnitude; and impedances in the base circuit appear β times smaller at the emitter. Here we have β , the inverse ratio of the signal currents at base and emitter, also relating the ratio of impedances seen at these points; the signal voltage across the impedance is therefore the same whether viewed from the base or emitter. The resistance between base and emitter of the "black box" is designated $r_{b'e}$, so according to the rule has a value

$$r_{b'e} = \beta r_e \dots\dots\dots (3)$$

In our example we took $\beta = 50$, so $r_{b'e}$ is $50 \times 6 = 300$ ohms. r_e fails to appear in the "black box" because the equivalent circuit represents the common emitter configuration; the emitter is grounded and one can only look into the base with respect to the emitter and see, of course, $r_{b'e}$.

In practice there is in addition to $r_{b'e}$ an extrinsic ohmic resistance $r_{bb'}$ associated with the base emitter junction. It is inevitable that there should be resistance in the path connecting the base terminal to the actual operative base region, but the true position of the active base region may be a little difficult to pin down, the border between ohmic base resistance and active junction area being rather indeterminate. There can also be some difficulty in measuring $r_{bb'}$ and information on it is unfortunately left out of many data sheets. Its effect is to increase the base input resistance to $r_{b'e} + r_{bb'}$ and the emitter resistance to $r_e + \frac{r_{bb'}}{\beta}$. The former happens to be denoted

by the resistive part of the h-parameter h_{ie} and the latter by h_{ib} (resistive part), and it will be noticed that in the presence of $r_{bb'}$ neither of these is exactly inversely proportional to the collector current. At high values of collector current when the extrinsic resistance becomes predominant, the behaviour of the transistor is far from the ideal " $r_{bb'}$ -less" transistor.

There is also an ohmic resistance in series with the emitter lead, but again this is insignificant except at high collector currents where, strictly it should be

added to $\frac{r_{bb'}}{\beta}$. This emitter resistance together with

the series collector resistance accounts for the knee voltage of the collector characteristics. Below the knee both junctions are forward conducting (the bottomed state) and each curve of the family of characteristics merges into a line roughly through the origin of slope equal to the reciprocal of the sum of the emitter and collector extrinsic resistances (the collector saturation resistance). The extrinsic resistances vary somewhat with current and the line into which the characteristics merge below the knee is not precisely straight. The collector extrinsic resistance in particular may increase markedly under non-bottomed conditions, but the effect will be masked by the high collector *intrinsic* resistance.

A few of the occasions where account may need to be taken of $r_{bb'}$ and the emitter extrinsic resistance are now listed.

(1) Where a transistor is operated at a medium or high collector current for the transistor and the value of $r_{bb'}$ becomes comparable to $r_{b'e}$. Transistors with higher power ratings generally have correspondingly lower values of extrinsic resistance.

(2) In switching circuits where $r_{bb'}$ may limit the base current and influence the turn-on and turn-off speeds.

(3) In high-frequency applications where the input capacitance has to be treated as being behind $r_{bb'}$. In matching to a signal source, $r_{bb'}$ will be found to have an influence on the noise performance.

Example of a Voltage Amplifier:—Following the manner in which the gain of a pentode stage is shown to be $g_m R_L$, it will be anticipated that the voltage gain of a transistor stage with collector load R_C will be close to $g'_m R_C$. (From this point, for clarity, the resistance $r_{bb'}$ will be dropped from our considerations.) Suppose a collector load resistor, R_C , of 1.2k Ω is added to our example. As $g'_m = 160$ mA/V, the voltage gain $g'_m R_C$ will be $160 \times 1.2 = 192$.

More accurately, where account is taken of the slope resistance at the collector, the gain is $g'_m R_C \times$

$$\frac{r_{ce}}{R_C + r_{ce}}$$

which, for a value of $r_{ce} = 18$ k Ω as adopted

later in the article, gives a slightly lower gain of 180. The idea of the signal current dividing between the output resistance and output load is no newcomer but it does appear in an additional form with transistors, as follows. Where an input current rather than voltage is defined, the current gain of the stage for zero R_C is simply β . When, however, R_C is not zero, the signal current divides between the output resistance and output load, and it has become customary to describe this effect as a lowering of the current gain with increasing collector load. There can be no argument here as the ratio of output current to input current as measured externally on the transistor obviously does depend on the collector load. The definition β is reserved for short circuit conditions at the collector.

If now we add a small resistor, R_E , of 12 ohms in series with the emitter lead a reduction in gain will be noticed. Stealing from valve practice the reduction would be expected to be by a factor of $1 + g'_m R_E$

to a new gain $\frac{g'_m R_C}{1 + g'_m R_E}$ in this case equal to

$$\frac{192}{1 + 1.92} = 66$$

(by the accurate calculation 62). The

first point to notice is that simply by adding such a small and seemingly insignificant resistor the gain is dropped by a factor of 3. But, of course, g'_m is

large and r_e only 6 ohms. In fact, $\frac{g'_m R_C}{1 + g'_m R_E}$ may

be written as $\frac{R_C}{R_E + 1/g'_m}$ or as $\frac{R_C}{R_E + r_e}$. The signal voltage

can now be considered as appearing across R_E and r_e in series, and, taking the emitter signal current as equal to the collector signal current, the voltage gain is seen, quite clearly, as the ratio of the two impedances. The interpretation is that whatever signal current flows in at the emitter appears, in phase, again at the collector. In the first example where R_E was zero, the voltage gain can be written as

$$\frac{R_C}{r_e}$$

which as $r_e = \frac{1}{g'_m}$ brings one back to $g'_m R_C$.

In the presence of R_E the original gain could be restored by decoupling the emitter. A large value

of decoupling capacitor would be needed at low frequencies whatever the value of R_E as r_e is the impedance that is truly being decoupled. This should bring back haunted memories of valve practice where the cathode bypass capacitor actually

decouples R_K in parallel with $\frac{1}{g_m}$, the latter generally

being the predominant factor. For transistor designs it is often wise not to bypass the emitter resistance or perhaps to bypass only part of it. In the latter case the capacitor needed is not quite so large, for r_e has been artificially increased. The great benefit accruing from this is a smaller dependence on transistor characteristics; the voltage gain is given more specifically by the external resistors employed. Furthermore, as R_E is not dependent on collector current, the gain varies less with changing I_C . This is the point which was relevant earlier when it was mentioned that emitter degeneration improved linearity.

At the emitter we have r_e in series with R_E . According to the notion that impedances are multiplied up by a factor β when viewed from the base, the resistance seen by the input signal will be

$$r_{b'e} + \beta R_E \quad (4)$$

This is a quantity showing less dependence on I_C and $r_{b'e}$ which again demonstrates that the stage is becoming more akin to a linear voltage amplifier. When the source resistance driving the stage is small compared to $r_{b'e} + \beta R_E$, the stage will behave as a voltage amplifier. Should the source resistance be high compared to this, the proportion of signal voltage developed across $\beta(r_e + R_E)$ will be directly proportional to β as will therefore be the output voltage. Alternatively we have simply a current gain of β and a signal voltage out at the collector of βi in R_C . Generally speaking, it is undesirable to allow the gain of an amplifier to be dependent on the current gains of the transistors used as the variation in possible β is so great.

We are now very much on the first rung of the ladder towards successful circuit design. It is considerations of current and voltage gain together with circuit impedance which enable the performance to be visualized. Switching circuits including oscillators will, when passing through intermediate states, demand this knowledge just as much as straight amplifiers. There is, of course, a sharp transition in impedance magnitudes when cut off or bottomed conditions are reached, but in all three states one needs to know what the loading effects are and whether they are dependent on the operating point or selection of transistor. Take, for instance, the input resistance $r_{b'e} + \beta R_E$ at the base of a stage with emitter resistor R_E ; the whole of this is proportional to the current gain and the first

part also to $\frac{1}{I_C}$. It would be pointless having a stage preceding this which was at all critical on loading.

Our investigations into the "black box" will therefore proceed a little deeper to find all the useful impedances which could influence the design, and then next month a few examples will be given embodying the concepts raised. The equally important side of design work of determining bias networks and of evaluating the effects of temperature on the operating point will be left to the third and fourth articles. It is thought that little guidance should

be necessary over procedures for checking voltage, current and power ratings of devices¹ and, beyond a mention of some terms for voltage ratings, this rather dull aspect will be taken as read.

Still confining our attention to the base emitter junction, and restating the input resistance found at (4) in a new form, we have:

Input resistance of emitter follower

$$= r_{b'e} \left(1 + \frac{\beta}{r_{b'e}} R_E \right) = r_{b'e} (1 + g'_m R_E)$$

Compare this to the approximate input resistance of a cathode follower, $R_E(1 + g_m R_K)$, and the correspondence is immediately apparent. This should warm the heart of a die-hard valve man. On a point of practical usage, the quantity R_E must, of course, include all the a.c. loading by subsequent circuitry at the emitter. Next, if R_S is the total source resistance between base and ground, the output resistance at the emitter will be found by dividing by β , giving

$\frac{1}{\beta}(r_{b'e} + R_S)$ or $r_e + \frac{R_S}{\beta}$. This, of course, is in parallel with R_E . Note that the resistance looking into the emitter is only r_e when R_S is zero. In all

these expressions $r_{bb'}$ should be added to $r_{b'e}$ or $\frac{r_{bb'}}{\beta}$

to r_e if thought significant. The marked interdependence of input and output circuits has come clearly to light here. A low output resistance from an emitter follower is achieved when the source resistance is low, a high input impedance when R_E is large. But to what extent does the condition at the collector terminal affect these results? Unlike a valve, there is in our "black box" a resistive path from collector to base, namely $r_{b'c}$. In the presence of a collector load $C_{b'c}$ increases the input capacitance by Miller feedback and, of the two feedback paths, this is the one which needs the most careful vigilance. $r_{b'c}$ can, however, make a 2:1 difference in the input resistance, but as we shall see in a moment, the occasion rarely actually occurs.

Voltage Amplification Factor:—Before continuing with Miller feedback an unusual and possibly novel parameter for transistor work will be introduced. This is the voltage amplification factor (the theoretical maximum gain figure) for which the symbol μ will be adopted to be in accordance with valve nomenclature. From the definition of the parameter, it must follow that $\mu = g'_m r_{ce}$. It so happens that, in addition, μ closely gives the ratio of the two "black box" resistances $r_{b'c}$ and $r_{b'e}$.

$$\text{We have } \mu = g'_m r_{ce} = \frac{r_{ce}}{r_e} \text{ and } \mu = \frac{r_{b'c}}{r_{b'e}} \quad (5)$$

From stating these relationships, it is possible to go on and demonstrate the well known variations of impedance at the collector. Consequently it is hoped that the reader will find the concept of μ a useful aid for visualizing transistor behaviour. It is seen from

the second expression for μ that $\frac{r_{b'c}}{r_{b'e}}$ is the ratio

of the two series connected resistances joining collector to emitter, $r_{b'c}$ being much greater in magnitude than $r_{b'e}$, the reciprocal of μ represents the attenuating factor by which a signal voltage at the collector is fed back to the base. If μ were numerically 3000,

then $\frac{1}{3000}$ of the output signal would find its way back

TABLE I (Some easily remembered equations).

		In our example $I_0 = 4\text{mA}, \beta = 50, \mu = 3000$	Resistive component of h parameter
Mutual conductance	$g'_m = 40\text{IcmA/V}$ (I_0 in mA)	$g'_m = 160\text{mA/V}$	
Emitter resistance	$r_e = \frac{1}{g'_m} \text{ k}\Omega = \frac{25}{I_0}$	$r_e = 6\Omega$	$h_{ib} = r_e + \frac{r_{bb'}}{\beta}$
Current gain	$\beta = g'_m r_{b'e}$	$\beta = 50$	$h_{fe} = \beta$
Base to emitter resistance	$r_{b'e} = \beta r_e$	$r_{b'e} = 300\Omega$	$h_{ie} = r_{b'e} + r_{bb'}$
Amplification factor	$\mu = g'_m r_{ce}$	$\mu = 3000$	$h_{re} = \frac{1}{\mu}$
Collector to emitter resistance	$r_{ce} = \mu r_e$	$r_{ce} = 18\text{k}\Omega$	$h_{oe} = \frac{2}{r_{ce}}$
Collector to base resistance	$r_{b'c} = \mu r_{b'e}$	$r_{b'c} = 900\text{k}\Omega$	$h_{ob} = \frac{2}{r_{b'c}}$
Also	$\beta = \frac{r_{b'c}}{r_e} = \frac{r_{b'e}}{r_{ce}}$		
	$\mu = \frac{r_{ce}}{r_e} = \frac{r_{b'c}}{r_{b'e}}$		

to the input. $1/\mu$ therefore acquires the name voltage feedback factor or reverse voltage transfer ratio. This is the h-parameter h_{re} , and $h_{re} = \frac{1}{\mu}$.

The voltage feedback factor is generally treated as one of the fundamental parameters describing a transistor and although there may be sound theoretical reasons for doing this, its numerical value is a trifle small—a couple of zeros appear after the decimal point. μ , a number in the thousands, would seem to be much handier. Regrettably, the voltage feedback factor has in the past also been dubbed by the symbol μ , the inverse of the μ we have defined by way of the amplification factor. (See, for example, pages 46 and 82 of reference 2).

There is one more relation involving μ to produce before we can be said to have all the "black box" parameters tied up. In equation (3) it was established that $r_{b'e} = \beta r_e$ and in (5) that $\mu = \frac{r_{ce}}{r_e} = \frac{r_{b'c}}{r_{b'e}}$, and from these it is apparent that $r_{b'c} = \frac{r_{b'e} r_{ce}}{r_e} = \beta r_{ce}$.

In our running example it has so far been determined that $r_e = 6\Omega$ and $r_{b'e} = 300\Omega$; now taking a value of 3000 for μ , we have $r_{ce} = 18\text{k}\Omega$ and $r_{b'c} = 900\text{k}\Omega$. All the results appear in Table I and these show that a certain symmetry is taking shape in the equivalent circuit. In proceeding from r_e to $r_{b'e}$ one multiplies by β , and this is again so in proceeding from r_{ce} to $r_{b'c}$. Furthermore the jump from r_e to r_{ce} is by a factor of μ and this is again so for the jump from $r_{b'e}$ to $r_{b'c}$. Indeed, by multiplying by factors of β and μ , we can, so to speak, climb up the ladder of resistance magnitudes of the equivalent circuit. Expressing each parameter in terms of r_e one can write $r_{b'e} = \beta r_e$, $r_{ce} = \mu r_e$, and $r_{b'c} = \beta \mu r_e$. And, as anticipated earlier, $r_{b'e}$, r_{ce} and $r_{b'c}$ are all inversely proportional to the collector current just as r_e is. The other parameter that r_e is sensitive to is temperature, but as this depends on the temperature change expressed as a percentage of the absolute temperature, the effect is only small for (say) a 50°C . change around room temperature. μ has a similar dependence on temperature; β , on the other hand, has a far more significant variation and will be discussed in a later issue. Measurements on a transistor curve tracer of the product of collector resistance and collector current inferred a small increase of μ with rising current, but the order of magnitude remained sensibly constant.

By controlling the degree of base width modulation by the collector voltage ("Early effect"), the manufacturer has a control over the magnitude of μ .

We see that the main environmental influences on the "black box" parameters are temperature and collector current. It is particularly the reciprocal dependence of the resistive elements on I_0 which should be borne uppermost in mind. Of course, temperature has other very significant effects on base emitter voltage and leakage current, but these are subjects which will be treated in the following articles.

Back to Miller feedback and the input resistance of a common emitter stage. Suppose a stage gain as high as μ were to be achieved. The input would be shunted by a resistance $\frac{r_{b'c}}{\mu + 1}$, or, to sufficient accuracy,

by $\frac{r_{b'c}}{\mu}$. This equals $r_{b'e}$, so the input has a further resistance $r_{b'e}$ effectively across it, giving an actual input resistance of $\frac{r_{b'c}}{2}$. In the presence of an emitter

resistor R_E , the stage gain is reduced to $\frac{\mu}{1 + g'_m R_E}$

so that the shunting resistance is $\frac{r_{b'c}(1 + g'_m R_E)}{\mu}$

which equals $r_{b'e} + g'_m r_{b'e} R_E$ or $r_{b'e} + \beta R_E$. This is the same as equation (4), so the input resistance is again reduced by a maximum factor of 2. But it would be a most unusual circuit which produced a stage gain high enough to give a noticeable effect. The collector characteristics are pentode-like in character (although without any screen current to contend with at the emitter), and a collector load comparable to r_{ce} would necessitate something other than a plain resistor in this position—a very high Q tuned circuit for instance. So with a clear conscience equation (4) may be taken as truly representative of the input resistance at the base.

In the next article our investigations will be continued and the important aspects of some practical circuits investigated on the basis of our discoveries so far.

REFERENCES

1. "The Use of Semiconductor Devices" issued by VASCA — the Electronic Valve and Semiconductor Manufacturers' Association, 1961.
2. "The Junction Transistor and its Applications" edited by E. Wolfendale (Heywood, 1958).

NATIONAL TV & RADIO SHOW

AFTER a lapse of two years the National Television and Radio Show—to give it its full title—opens at Earls Court on Monday, 24th August, but for the first two days admission is restricted to *bona fide* dealers, members of the trade and invited guests. The first public day is the 26th when the Show will be officially opened at 12.0 by Lord Hill, chairman of the I.T.A. Admission to the Show, which costs 4s (children 2s 6d), is also restricted to the trade for the first hour and a half each morning (until 11.0) except on both Saturdays and Friday, September 4th. It closes at 9.0 p.m. each day.

In the following pages we have surveyed stand-by-stand the technical exhibits. This survey has been prepared from information provided by the exhibitors but there may well be the last-minute announcement of some outstanding item after we have gone to press. However, it is hoped that, together with the list of exhibitors and plan opposite, it will provide a useful guide for readers attending the show. For those unable to visit the show it should give a general picture which will be supplemented by a more detailed review in our next issue of some of the trends shown.

It must be underlined that this is a *national* show and therefore some of the sets recently introduced by one or two British manufacturers are not eligible for

inclusion as they are made overseas or have too large a content of foreign components.

The area covered by the exhibition is smaller than in the past although the number of exhibitors is only ten fewer than at the last show. The total number is 74. Most of them are manufacturers of domestic sound and television equipment and accessories, the remainder include the Services, B.B.C., I.T.A., G.P.O., publishers and those providing services for the industry.

In addition to the stands occupied by the exhibitors listed opposite there are several exhibition features. The one concerned with careers consists of a theatre, holding about 120 people, in which will be shown a film, "A dream of a job," specially prepared by the B.R.E.M.A. Service Managers Committee. It shows the opportunities offered in the servicing side of the radio and electronics industry.

To enable exhibitors to demonstrate television receivers, signals received "off the air" and by land line from both the B.B.C. and I.T.A. are being distributed to the stands from a control room equipped by Belling & Lee. In the control room there are also two film scanning units feeding 405- and 625-line signals into the distribution system. For the demonstration of sound receivers some 30 induction loops have been installed.

Guide to the Stands

ACE (24)

A stereo radiogram, the Venetia, incorporating a nine-valve receiver covering the long- and medium-wave bands and v.h.f., is introduced. Another new Ace radiogram is the AG636. The company's Promenade six-transistor portable covering the m.w. and l.w. bands is being featured. Also on show is the Argosy Clubman transistor portable which is similarly housed in a $8\frac{3}{4} \times 2\frac{1}{2} \times 5\frac{1}{2}$ in case, but has a telescopic aerial.

Ace Radio, Footscray, Kent.

AERIALITE (72)

Battery-powered aerial amplifiers, both for indoor and outdoor installation, for the v.h.f. and u.h.f. bands are being featured by Aerialite who are also showing two new mains-operated transistor amplifiers for small television distribution schemes. A selection of Aerialite's wide range of "Golden Gain" aerials for each of the television bands is also shown.

Aerialite Ltd., Castle Works, Stalybridge, Cheshire.

ALBA (70)

Two new television receivers are presented and these are available with or without u.h.f. tuners. The receivers are based on plug-in modules for ease of service and both are high-gain types for fringe-area reception. Of the four transistor radio receivers shown, the Olympic with

short-wave reception facilities is put forward as enabling listeners to receive the Olympic Games commentaries from a wide variety of alternative sources. The display is completed with record players and tape recorders.

Alba (Radio and Television) Ltd., Tabernacle Street, London, E.C.2.

AMALGAMATED ELECTRIC (27)

The full range of service aids offered is being shown and demonstrated to trade visitors. Apart from the new equipment on show, which includes two new tools for printed circuit servicing and a d.c. power supply for transistor equipment, a continuous demonstration is being given on the repair of tuner units.

Amalgamated Electric Services Ltd., Waddon Factory Estate, Croydon, Surrey.

ANTIFERRENCE (43)

A comprehensive selection of v.h.f. and u.h.f. aerials and aerial accessories is shown. The new models include two combined u.h.f./v.h.f. aerials—the "Unitop" for set-top use and the "Uniray" for outdoors. The latter has a single Band I dipole, a three-element Band III section and nine-element u.h.f. section. Separate cable junctions are provided for v.h.f. and u.h.f. downleads and, in common with all their u.h.f. arrays, a balun is incorporated. For those areas where both B.B.C. and I.T.A.

operate in Band III but in widely separated channels a broadband array has been produced with either five or eight elements.

Antiferrence Ltd., Bicester Road, Aylesbury, Bucks.

ARGOSY

(see Ace stand 24)

ARMY (26)

The Royal Corps of Signals is staging a display on this stand which shows various aspects of the Army communications system. Examples of typical equipment used by the Army are on show. A large illuminated diagram illustrates the worldwide radio communications system developed for the Services and linking the U.K. with the Commonwealth forces. A communications centre, operated by the W.R.A.C. Signals Branch, has been set up on the stand and is linked into the world system. Closed-circuit television is now used to provide all staff officers in a field H.Q. with up-to-the-minute details of the central operations map.

Ministry of Defence, Old War Office Building, Whitehall, London, S.W.1.

B.B.C. (78)

In the past the B.B.C.'s stand has been devoted mainly to entertainment, but this year it is aimed at helping the dealer, both directly and indirectly. In addition to the usual

(Continued on page 440)

LIST OF EXHIBITORS

Ace Radio	24	Garrard Engineering	5	Newiste—see Goldsmith	47
Aerialite	72	Goldsmith, N., & Co.	47	Newnes	53
Alba (Radio & Television)	70	Greater London Fund for Blind...	31		
Amalgamated Electric Services ..	27			Pam (Radio & Television)	3
Antiference	43	Hacker Radio	73	Perdio Electronics	20
Argosy—see Ace Radio	24	Heathkit—see Daystrom	32	Peto-Scott—see Stella	69, X7
Army	26	Heywood & Co.	29	Philips Electrical	21, 61, X2
		His Master's Voice—see Brit. Radio Corp.	42, X6	Pye	76, X12
B.B.C.	78				
B.M.B. (Sales)	50	I.T.A.	37	R.A.F.	9
Barclays Bank	71	Iliffe Electrical Publications	56	R.G.D.	4
Belling & Lee	16	Invicta Radio	33	Radio & Allied Industries	14, X11
Brimar—see Thorn-AEI	64, X14	J-Beam Aerials	25	Radio & Television Services	62
British Radio Corporation ...	42, X6			Rediffusion Vision	57
Bush Radio	59, X17	Keith Prowse & Co.	1	Regentone Radio & Television	12
		Kodak	28	Revelation—see Wood	48
Co-operative Wholesale Soc.	35	Kolster-Brandes	19, X18	Roberts' Radio Co.	40
Cossor Radio & Television ...	36, X16			Royal Navy	7
		Labgear	54	Stella Radio & Television Co.	69, X7
Dansette Products	58	Linguaphone Institute	45		
Daystrom	32	Lloyds Bank	11	T.V. Publications	17
Decca Radio & Television	39, X10	McMichael—see Radio & Allied Industries	14, X11	Tape Recorders	65
Defiant—see Co-op Wholesale Soc.	35	Marconiphone—see Brit. Radio Corp.	42, X6	Territorial Army	26A
Display Electrics	51	Markovits	2	Thorn-AEI Radio Valves & Tubes	64, X14
Dynatron Radio	60	Masteradio—see G.E.C.	15, X11		
		Mazda—see Thorn-AEI	64, X14	Ultra Radio & Television	41, X4
E.M.I. Tape	55	Mercantile Credit Co.	6		
Econasign Co.	52	Metropolitan Police	77	Westminster Bank	10
Ekco Radio & Television	68, X8	Midland Bank	22	Wireless for the Bedridden	79
Ever Ready Co.	75	Mullard	38, X15	Wireless & Electrical Trader	56
		Murphy Radio	34, X17	Wireless World	56
Ferguson Radio Corporation	67, X13	National Provincial Bank	66	Wood, W., & Sons	48
Ferranti Radio & Television ...	13, X1				
Fidelity Radio	74, X9				
Fountain Press	44				
G.E.C. (Radio & Television) ...	15, X11				
G.P.O.	63				

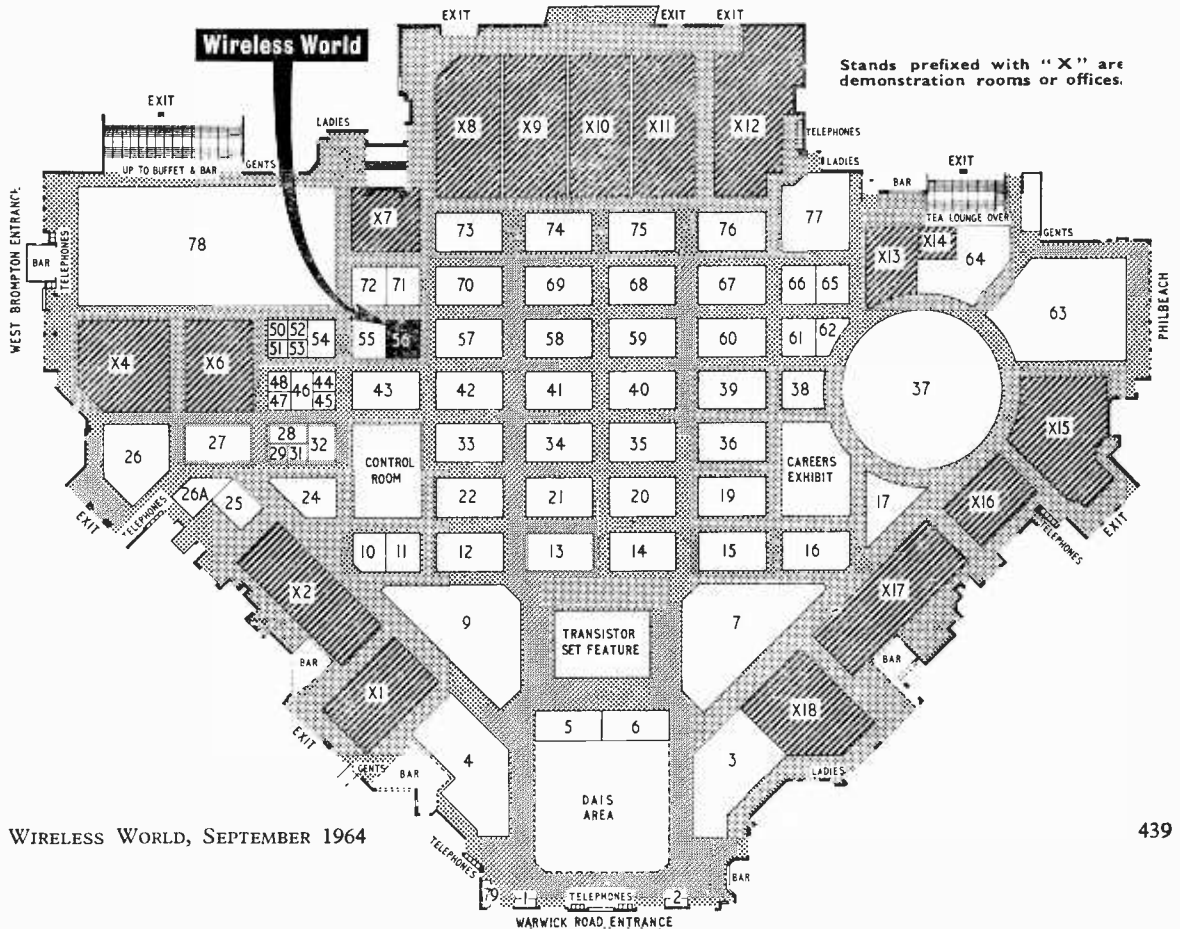

engineering information counter there is a trade reception area and consulting rooms. The importance of correct set and aerial installation for the reception of BBC-2 is featured in a demonstration in which visitors can participate. To illustrate the quality of B.B.C. sound broadcasting the output from a typical studio and control room is fed to an adjacent "living room" in which listeners are shown what to do and what not to do if they want to receive the quality of the transmitted programme.

British Broadcasting Corporation, Broadcasting House, London, W.1.

B.M.B. SALES (50)

B.M.B. are exhibiting a complete range of sapphire and diamond styli. Other exhibits this year include record racks, cases, albums, cleaning cloths and other accessories. A "Needle Clinic" service for advice is available to visitors.

B.M.B. (Sales) Ltd., Fleming Way, Crawley, Sussex.

BELLING & LEE (16)

A selection from their range of u.h.f. and v.h.f. arrays, distribution equipment and mast-head amplifiers is on show. Both the original Band IV and the new Band V u.h.f. aerial arrays on show adopt the Belling-Lee build-up principle, and the v.h.f. arrays are represented with a series of Band III broad-band aerials. A typical B.B.C. transmitting/receiving aerial is also featured in this year's display.

Belling & Lee Ltd., Great Cambridge Road, Enfield, Middx.

BRIMAR

(see Thorn-AEI stand 64)

BRITISH RADIO CORP. (42, X6)

A feature of this year's display of television receivers is the new Thorn Type 900 cool chassis which is fitted to three models in the H.M.V. range and two in the Marconiphone range. Heat has been considerably reduced in this type of chassis by using an autotransformer in place of the conventional ballast resistor, and also by

using only a single printed circuit board at the bottom of the cabinet. Transistor portables, record players, radiograms and tape recorders under the brand names H.M.V. and Marconiphone are also shown.

British Radio Corporation Ltd., 21 Cavendish Place, London, W.1.

BUSH (59, X17)

Believing that, despite the ubiquitous transistor set, there is still a place for the mains-operated valve receiver, Bush have introduced the VHF81—an a.c./d.c. superhet covering the v.h.f. band and the long- and medium-wave bands. It has a.g.c. on all three wavebands and built-in aerials, but also has provision for the use of an external aerial on the v.h.f./f.m. band. The latest in the Bush series of transistor portables is the TR112, which covers both the l.w. and m.w. bands. It measures $9\frac{1}{2} \times 13\frac{1}{2} \times 3\frac{1}{2}$ in, employs seven transistors and two crystal diodes and a 6-in elliptical speaker. The SRG 110 stereo radiogram has two matched output stages, each delivering 2.5 watts. Housed in a 33in wide \times 29in high cabinet, the four-speed record changer is on a shelf below the superhet receiver which covers v.h.f., m.w. and l.w. bands. All Bush television receivers are available with or without a u.h.f. tuner.

Bush Radio, Power Road, Chiswick, London, W.4.

CO-OPERATIVE WHOLESALE SOCIETY (35)

A feature of this year's display is their first all-transistor a.m./f.m. radiogram, the AF 85. Mechanical features of the chassis are somewhat unusual in as much as the scale backing plate is used as the holding structure for all the printed boards, heat sink for the output stage and tuner fixing, in addition to its usual function of pointer carriage and control mounting. Automatic frequency control can be provided for the f.m. tuner, which covers 87 to 101 Mc/s. Ease of servicing is the main feature of the range of television receivers on show. Everything is easily removed, and the wrapped wire technique is used for inter-board connections. Transistor portables, record players and tape recorders are also on show.

Co-operative Wholesale Society Ltd., Radio and Television Department, Alma Park, Warley Street, Upminster, Essex.

COSSOR (36, X16)

Five dual-standard television receivers are shown this year. Both the slim-line receivers, the CT 1972A with a 19-in screen and the CT 2372A with a 23-in screen, have their controls and speakers fitted on the side, and have been designed to fit into the limited spaces available in flats and maisonnettes. Width dimensions for this year's 19- and 23-in receivers range from $22\frac{1}{4}$ to

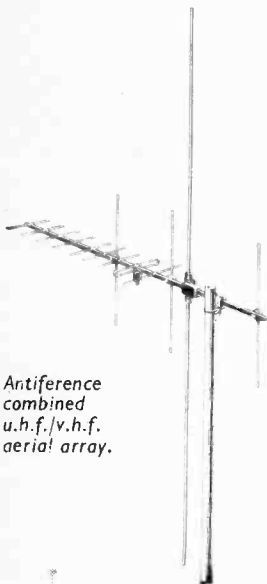

Antiference combined u.h.f./v.h.f. aerial array.

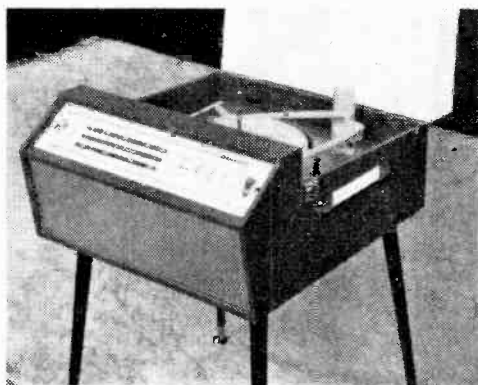

Duchess radiogram from Dansette Products.

Decca Model RP205 record player.

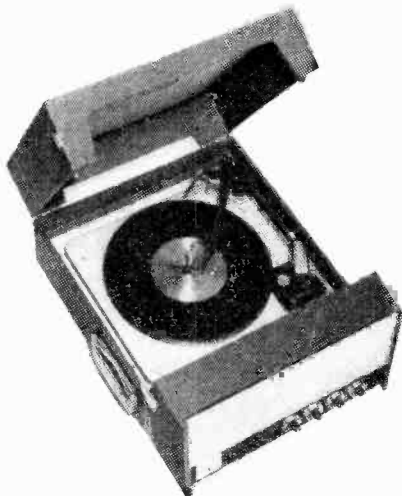

"Olympic" three-waveband transistor receiver from Alba.

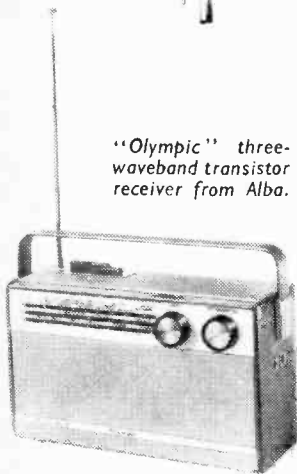

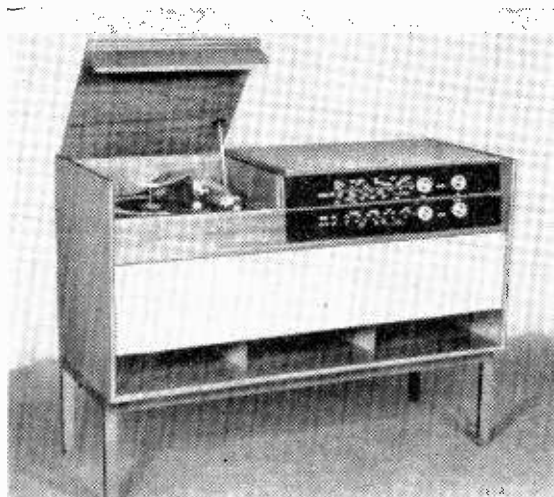

Transistor radiogram Model AF85 from Co-operative Wholesale Society.

30½ in. Three radiograms are being shown, two of which are making their first public appearances. Once again, consideration has been given to the saving of space, with a new model which measures 13 in from front to rear and only 31 in wide. This has been achieved by mounting the player unit on a drop-front flap. To balance this compact model, the other new radiogram, the CR 1508A, is 4 ft wide and is fitted with a four-waveband receiver and stereo player unit with two 10×6 in speakers. Four different radios, two battery portables and two mains, complete this year's range.

Cossor Radio & Television Ltd., 233 Tottenham Court Road, London, W.1.

DANSETTE PRODUCTS (58)

Among the new models this year is the Empress tape recorder. It is a four-track, three-speed machine fitted with a sound level meter in place of the conventional magic eye. A type TD 10 tape deck with full track-to-track superimposition facilities is used. The amplifier section, as with a number of other tape recorders at the Show, can be used on its own. Following the popularity of the Monarch record player, Dansette have introduced a companion piece in the form of the Duchess RG65 radiogram. This model's player section has all the features of the Monarch series, which include automatic record changers and provisions for stereo. The radio section of the Duchess covers the long- and medium-wave bands, the latter is split into two (190-250 and 200-550 metres). A number of new transistor portables are also demonstrated.

Dansette Products Ltd., Honeypt Lane, Stanmore, Middx.

DAYSTROM (32)

Some 60 items are shown all of which may be constructed from kits

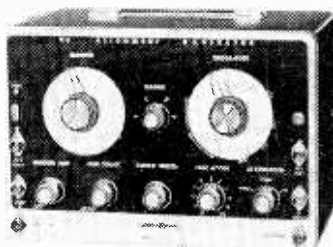

Heathkit television alignment generator model HFW1 available from Daystrom in kit form or ready made.

of parts. The range includes transistor sound radio receivers, test gear, high-quality audio equipment and outdoor aerial-mast assemblies. The display includes a demonstration of Heathkit equipment construction. Features of the public-address/guitar amplifier kit shown include 4 inputs, 50W output, variable tremolo-speed control and two 12-in loudspeakers. The new television alignment generator, HFW-1, employs a non-mechanical sweep oscillator system. Its built-in variable marker oscillator covers from 19-60 Mc/s on fundamentals and 57-180 Mc/s on calibrated harmonics.

Daystrom Ltd., Gloucester.

DECCA (39, X10)

Transistor radios, dual-standard television receivers, stereograms, record players and a representative selection of audio equipment from the Special Products Division are on display. Four new television receivers have been added to their current range which includes two table models and six consoles—four of which have full-length double doors. A feature of the Decca range of stereograms and record players is the latest development of the Deram cartridge.

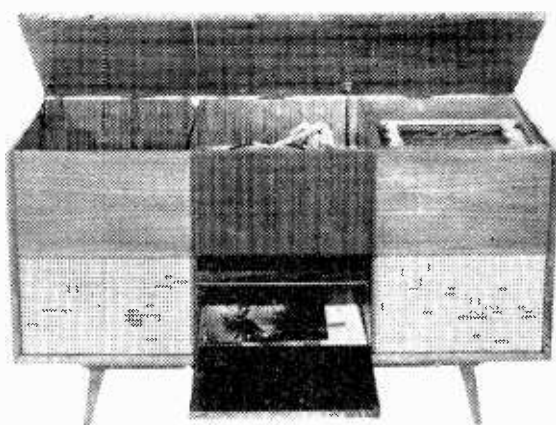

Henley Model RG33W radiogram from Dynatron.



Bush Radio have introduced a table-model mains-operated superhet (VHF81) covering l.w., m.w. and v.h.f. bands.

This, which is claimed to have good channel separation and a wide frequency range, is fitted to most models, including the RP 205 record player, which is a mono unit with stereo facilities. A self-contained unit incorporating an amplifier and loudspeaker system identical to the RP 205, and similarly styled, is available under the model number SC 200.

Decca Radio and Television, Ingate Place, Queenstown Road, London, S.W.8.

DEFIANT

(see Co-operative Wholesale Soc. stand 35)

DISPLAY ELECTRICS (51)

A variety of interchangeable illuminated signs are on show including the "Newsreel" which gives a continuously moving display. Each of the signs employs easily fitted translucent letters, symbols, etc.

Display Electrics Ltd., 59 Lansdowne Place, Hove, Sussex.

DYNATRON (60)

Thirteen stereo radiograms head the Dynatron display this year. The deluxe group offers a five-waveband radio tuner covering long-, medium- and two short-wave bands plus the

f.m. band. These tuners are adaptable to multiplex and stereo radio broadcasts, a socket being provided to plug in a multiplex decoder. The sound output is rated at 7.5 watts per channel. Eight television receivers, seven record players and three transistor portables are also included in the display.

Dynatron Radio Ltd., Maidenhead, Berks.

E.M.I. TAPE (55)

Video and audio tape and accessories, as well as magnetic recording film, are being shown. Demonstrations are being given showing how a tape recorder can be linked to a projector to provide a commentary on a series of colour slides. John Borwick's book "Emitape Guide to Better Recording" is on sale.

E.M.I. Tape Ltd., Blythe Road, Hayes, Middx.

ECONASIGN (52)

A selection of Econasign transparent stencils for showcards, posters, notices, etc., are on show. These stencils, the manufacturers claim, overcome the disadvantage of ordinary stencils which leave portions of the letters incompletely printed.

The Econasign & Co. Ltd., 19-21 Palace Street, Victoria, London, S.W.1.

EKCO (68, X8)

The new range of Ekco radios, radiograms, record players and television receivers is displayed. Several 19- and 23-in television sets are included in this year's range. Features of these dual-standard sets include push-button tuning for both 405- and 625-line operation, and plug-in flywheel sync units, which can make any standard set suitable for fringe operation in a few minutes.

Ekco Radio & Television Ltd., Southend-on-Sea, Essex.

EVER READY (75)

A prototype dry-battery-operated portable transistor television receiver with a 7-in rectangular tube is the *pièce de résistance* on this stand. This 405-line receiver, measuring 9×8×13in and weighing 16lb including the battery, is built around the Mazda V3271 tube, which has a deflection angle of 42°. The set is powered by Ever Ready's newly developed TV1 battery feeding a stabilized power generator. Power consumption is three watts and the life of the battery is approximately 40 hours at 2 hours a day. Among the transistor sound receivers exhibited is the Sky Tourer, a portable-cum-car set. When installed in a car it operates from the car battery and the 6×4in speaker delivers approx. 1 watt undistorted output; as a portable the output is 400mW. It covers the l.w. and m.w. bands.

Ever Ready Co. (Great Britain) Ltd., Hercules Place, London, N.7.

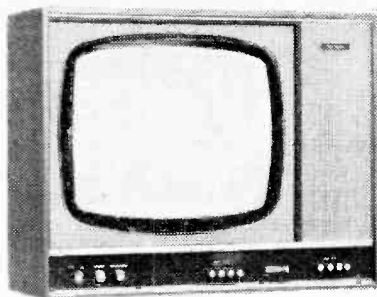

This 19-in table model can be seen on the Ferranti stand.

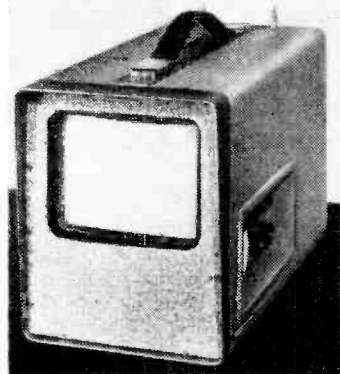

Ever Ready's prototype battery-operated television receiver.

FERGUSON (67, X13)

Two new, all-transistor, three-waveband radiograms have been added to this year's range. Both of these cover the long- and medium-wave bands and the f.m. band, and are fitted with stereogram units and dual 8×5in speakers. Five dual-standard television receivers fitted with the Thorn Type 900 series of cool-running chassis are highlighted. Two record players, two tape recorders and five transistor portables complete this year's exhibit.

Ferguson Radio Corporation Ltd., Thorn House, Upper Saint Martin's Lane, London, W.C.2.

FERRANTI (13, X1)

A selection of 19- and 23-in dual-standard television sets are on show. Included in the television display are two new rental receivers—one 19-in and one 23-in—and the Model T 1121. Push-button tuning for all bands with picture stabilization against mains fluctuations, separate pre-set contrast and horizontal hold controls, to ensure that picture readjustment is not necessary when changing channels, are features of this year's models. Supporting displays of radiograms and radios include two new auto-stereo grams, four transistor portables and two valve radios—a lightweight table receiver and a luxury model. Both of the radiograms are fitted with a

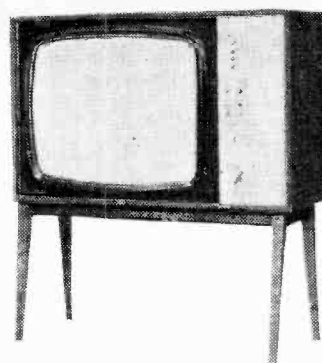

De luxe 23-in dual-standard receiver shown on the Ferguson stand.

radio tuner, covering long-, medium- and short-wave bands and the f.m. band, and twin amplifiers feeding four watts (per channel) into 8-in diameter speakers.

Ferranti Radio & Television Ltd., 41-47 Old Street, London, E.C.1.

FIDELITY (74, X9)

Three seven-transistor portables are on show this year. Two of these, the Model "208" and the Fulmar, have medium- and long-wave coverage and the third, which is on show for the first time, is also fitted with short-wave coils for the 5.5 to 15 Mc/s band. Known as the Galaxy this three-waveband model is fitted with a telescopic aerial for shortwave reception. The current range of Fidelity radiograms, record players and tape recorders is also shown.

Fidelity Radio Ltd., 6 Olaf Street, London, W.11.

G.E.C. (15, X11)

A highlight of G.E.C.'s radio display this year is the Transistomatic two-waveband portable radio combined with a Kodak Instamatic camera (19gn inclusive of a colour film, batteries for the radio and the flash, flash bulbs and a carrying strap). Several other portable radios are on show along with two radiograms and four new dual-standard television receivers. A number of sets carrying the Masteradio ensign are also being shown on this stand. Bandsread tuning is featured on their "Two-O-Eight" portable radio, which incidentally is also a feature of the G.E.C. Transistomatic and of a number of other sets at the Show. Two dual-standard 19-in television receivers and an a.m./f.m. stereogram are also included among the Masteradio exhibits.

G.E.C. (Radio & Television) Ltd., Langley Park, Slough, Bucks.

G.P.O. (63)

The dominating feature of the Post Office stand is a model of the radio tower nearing completion in the Tottenham Court Road area of London which will be the focal point for the inland telephone and television net-

work. The aerial at the Goonhilly station is also featured. Examples of Post Office research work, including electronic telephone exchanges, are also shown.

G.P.O., Headquarters Building, St. Martin's-le-Grand, London, E.C.1.

GARRARD (5)

A number of additions to the Garrard range of record turntables and transcription motors are being shown for the first time. Among the new units are two motors, the Model 401 and the Lab Series 80. This latter motor can be converted by the user into an automatic turntable simply by dropping into place an alternative record spindle. The Model 401 has a 61-lb machined turntable with gear-cut stroboscopic markings, which, illuminated by an integral bright neon lamp, enable the turntable speed to be checked and adjusted with extreme accuracy.

Garrard Engineering Ltd., New-castle Street, Swindon, Wilts.

GOLDSMITH (47)

Furniture suitable for supporting most types of table-top television and sound receivers can be examined. The table tops are made from $\frac{3}{8}$ in plywood and finished in a heat—and stain—resistant laminated plastic.

N. Goldsmith and Co. Ltd., Hope Mills, Pollard Street, Manchester 4.

G.L. FUND FOR THE BLIND (31)

On this stand, space for which is donated by the organizers, are shown examples of plastic mouldings produced by blind men and women for the radio industry. The Greater London Fund for the Blind makes a combined appeal on behalf of 14

voluntary blind organizations in the London area. At the last Radio Show (1962) the amount collected totalled £1,295.

Greater London Fund for the Blind, 2 Wyndham Place, London, W.1.

HACKER RADIO (73)

The latest in the Herald series of quality portables, the RP 30 has been styled in a more "contemporary" fashion. All the technical features have been retained in this nine transistor portable. Another new receiver in the Herald series is the Model RP 31SW. In addition to long- and medium-wave band coverage, this model covers 16.5 to 50 metres in the short waveband. Eleven transistors are used in the RP 31SW and the sensitivity of the shortwave band is high. A number of other transistor radios, record players and radiograms are included among this year's exhibits.

Hacker Radio Ltd., Norreys Drive, Cox Green, Maidenhead, Berks.

HEATHKIT

(see Daystrom stand 32)

HIS MASTER'S VOICE

(See British Radio Corp. stand 42)

I.T.A. (37)

The large area occupied by the Independent Television Authority is devoted mainly to booths covering the various aspects of Independent Television (including news gathering and schools programmes) and displays provided by each of the 14 programme companies that make up the I.T.A. network. In a large four-screen theatre is being shown a film

"Strictly Independent" providing a preview of some of the autumn programmes.

Independent Television Authority, 70 Brompton Road, London, S.W.3.

INVICTA (33)

The main feature of the display this year is the Invicta range of 19- and 23-in television receivers. All the models shown are dual-standard and push-button tuning for the u.h.f. bands is featured on the Models 7021 and 7041. The current range of transistor portables, record players and radiograms completes the display.

Invicta Radio Ltd., 100 Great Portland Street, London, W.1.

J-BEAM (25)

The new range of television aerials being shown by J-Beam features improved mechanical design with precision die-cast fittings and increased diameter crossbooms. The "Tribeam" series have composite arrays covering Bands I, III and IV/V and basically include a single dipole for Band I, a 3-element array for Band III and 6 elements for Bands IV and V, although they are available with extended arrays for long-range reception. All J-Beam u.h.f. arrays cover 13 channels and incorporate a balun and they are available with built-in transistor amplifiers. An improved version of the "Omnibeam" loft aerial is on show. It has a "Batwing" skeleton slot with two reflectors—one on either "wing" for Band III and a reactance-compensated dipole and adjustable reflector for Band I. J-Beam have introduced a rectangular skeleton slot with two reflectors for loft mounting in areas of high signal strength for Bands IV and V.

J-Beam Aerials Ltd., Westonla, Weston Favell, Northampton.

K.B. (19, X18)

Although by far the smallest of the K.B. range of television sets, the new transportable KV003, with an 11in tube, is the big attraction on the stand. It employs fly-wheel synchronization on both 405 and 625 lines, has a transistor u.h.f. tuner and extendable dipoles and "bow-tie" aerials. Two new transistor portable receivers make their debut at the show: they are the KR010 and KR012. The 010 is technically the same as the R.G.D. 210 covering the long-, medium- and short-wave bands, with bandspread tuning on 195-215 metres, and has a socket for a car aerial. The 012 has the same transistor line-up—mixer-oscillator overload protection diode, i.f., detector, pre-driver, driver and push-pull output—but has a 400mW output compared with the 010's 250mW. K.B. are also showing a table receiver employing eleven transistors and covering the l.w. and m.w. bands and the v.h.f. band. A battery

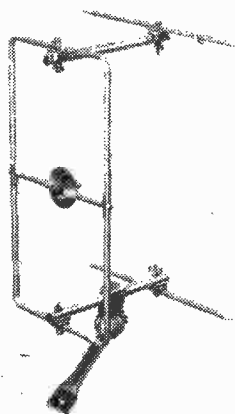

J-Beam loft "double-two" slot u.h.f. aerial.

The latest in the Herald series, the RP30, can be seen on Hacker's stand.

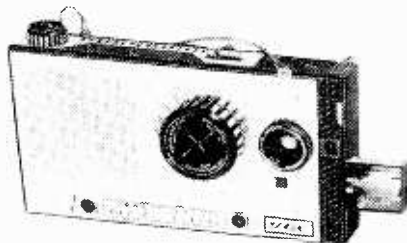

Transistomatic combined camera and portable radio from G.E.C.





Murphy "A Major" record player with a Garrard four-speed changer.



This McMichael radiogram can be seen on the Radio & Allied Industries stand.

eliminator is available allowing the receiver to be operated from the mains. The teak veneered cabinet measures $19 \times 9\frac{1}{4} \times 5\frac{1}{4}$ in.

Kolster-Brandes Ltd., Footscray, Sidcup, Kent.

KODAK (28)

On show for the first time is the Kodak P400 tape developed primarily for small-spool battery recorders and initially available on 3-in and $3\frac{1}{4}$ -in spools. The larger spool carries about 800ft and on a four-track recorder at $3\frac{1}{2}$ in/sec gives nearly three hours playing time. Demonstrations of linking sound recordings, using Kodak audio tape, with ciné and projected colour slides are given.

Kodak Ltd., Kingsway, London, W.C.2.

LABGEAR (54)

Although many types of aeriels are shown, the accent is on u.h.f. reception and amplification. Of the signal boosters demonstrated, battery-powered and mains-powered types are available. A mast-head u.h.f. amplifier is shown together with a 6-outlet u.h.f. television-signal distribution system.

Labgear Ltd., Cromwell Road, Cambridge.

LINGUAPHONE (45)

Home study language courses, recorded on 45 r.p.m. discs and in some cases also on tape, are available in 37 languages from the Institute.

Linguaphone Institute Ltd., Linguaphone House, 207-209 Regent Street, London, W.1.

McMICHAEL

(see Radio and Allied Industries stand 14)

MARCONIPHONE

(see British Radio Corp. stand 42)

MARKOVITS (2)

Badges, nameplates, self-adhesive labels and escutcheons are but a few of the articles to be seen on this stand. Manufacturers' name plates can be supplied in metal or plastic



Portable mains-operated television set KVOO3 introduced by K. B. A similar set is also available from R.G.D.



U.H.F. distribution amplifier from Labgear.

materials. A large range of "advertising novelties" is also displayed.

I. Markovits, 34 Stronsa Road, London, W.12.

MASTERADIO

(see G.E.C. stand 15)

MAZDA

(see Thorn-AEI stand 64)

METROPOLITAN POLICE (77)

Various exhibits and displays show different aspects of police work including the vital part played by communications and the rôle of science in police investigations.

Metropolitan Police, New Scotland Yard, London, S.W.1.

MULLARD (38, X15)

Circuit designs for hybrid (part transistor, part valve) television receivers for home and overseas, a design for an eleven-inch transistor dual-standard portable television receiver, methods of improving picture quality, and a range of designs for p-n-p/n-p-n audio amplifiers are among the working demonstrations to be seen on the Mullard stand this year. Also shown is a hybrid television receiver design suitable for

overseas markets where difficult fringe area reception is experienced. In this receiver automatic line and field synchronizing circuits provide a wide "catching" range, so improving picture stability under conditions of noisy reception and, at the same time, eliminating the need for hold controls. The a.g.c. circuit is "noise protected" by a frequency selective gate.

Mullard Ltd., Mullard House, Torrington Place, London, W.C.1.

MURPHY (34, X17)

The latest addition to the Murphy range is the "A Major" four-speed automatic record player. The 3-W push-pull amplifier feeds two speakers—an 8×6 in elliptical and a 4 in high-note unit. All Murphy television receivers employ stabilized line timebase and automatic gain control and have press-burton tuning on both v.h.f. & u.h.f. Heading the range of radiograms is the A891SR housed in a 54 in wide cabinet in which there are two loudspeakers at either end. These are fed by two matched push-pull output stages which are paralleled for radio recep-

(Continued on page 445)

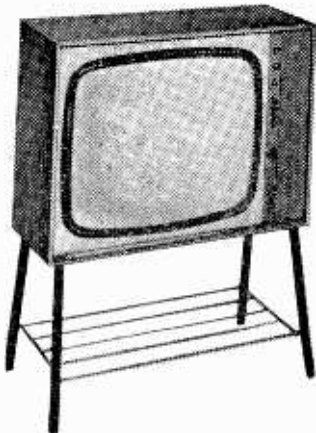

One of four 23-in receivers from the Pam range.

tion. A range of transistor portables is also on show.

Murphy Radio, Bessemer Road, Welwyn Garden City, Herts.

NEWISTE

(see Goldsmith stand 47)

PAM (3)

Large-screen sets are very prominent in the Pam television range this year. Four different 23-in models have been introduced, all of which are dual standard and available with or without u.h.f. tuners. Two new a.m./f.m. radiograms and several transistor portables and record players complete the display. Both the radiograms are fitted with Garrard autochangers, and in addition to covering the long- and medium-wave bands and v.h.f., the radio section of the Model 5208 covers the short-wave band.

Pam (Radio and Television) Ltd., 295 Regent Street, London, W.1.

PERDIO (20)

A battery-operated communications-type portable transistor receiver with continuous tuning from 1.6 to 30Mc/s plus m.w., l.w. and v.h.f. coverage, is introduced at the show. To be known as the Marco Polo, it employs 16 transistors with separate r.f. and i.f. circuits for a.m. and f.m. and a b.f.o. which may be switched in for c.w. reception. Perdio are also showing a transistor direction finder for yachtsmen, u.h.f. television boosters and a transistor television set.

Perdio Electronics Ltd., Bonhill Street, London, E.C.2.

PETO-SCOTT

(see Stella Radio and Television stand 69)

PHILIPS (21, 61, X2)

A wide range of radios, radiograms and television receivers are being shown. Four of the nine television receivers are on show for the first time. One of these, the Philips Combinado Model 23FG632A has,



Long-, medium- and short-wave coverage is provided by the R.G.D. eight-transistor RR210 portable.

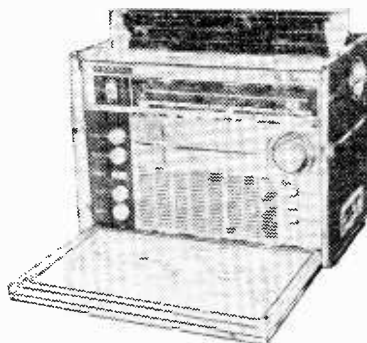

The Marco Polo sixteen-transistor portable introduced by Perdio.

in addition to 23-in television chassis, been linked with a five-band stereo radiogram into one cabinet with folding doors. One of the 10 x 6 in elliptical speakers is used for the television output. For the radiogram sound there are also two 3-in tweeters; output of the gram is three watts per channel. The radio section of this model covers two short-wave bands, the long- and medium-wave bands, and the f.m. band. A Philips four-speed automatic changer with push-button controls is used together with a Model AG3310 pickup head.

Philips Electrical Ltd., Century House, Shaftsbury Avenue, London, W.C.2.

PYE (76, X12)

Emphasis is given to 23-in, dual-standard receivers all of which incorporate "silver-contact" u.h.f. tuners. Record players for all types of users can be seen and also the Pye "Achoic" stereophonic system. This utilizes a cluster of six loudspeakers and a transistor amplifier providing 5W per channel. The pickup used in the system tracks at a pressure of 2gm and a retractable cartridge minimizes record damage if the arm is dropped on or skated across the record. In the realm of transistor portables, the Pye Poppet introduced at the show weighs 8oz uses six transistors and retails at 5gns.

Pye Ltd., St. Andrew's Road, Cambridge.

R.A.F. (9)

A mock-up of an air traffic control tower, with simulated arrival and departure of aircraft, is the main feature of this stand. There is also a model of the Fylingdales B.M.E.W.S. station. A section is devoted to apprentice training and another to the activities of the R.A.F. Amateur Radio Society.

Ministry of Defence (Air), Adastral House, Theobald's Road, London, W.C.1.

R.G.D. (4)

Transistor tuners, designed by their German associates Schaub Lorenz, which give an improved signal-noise ratio, are fitted in R.G.D. television sets 628 and 732, which respectively have 19-in and 23-in screens. A transportable 11-in screen dual-standard television receiver (RV203), with a specification the same as the K.B. KV003, is introduced at the show. The latest transistor sound portable is the RR210 which covers the l.w., m.w. and s.w. bands and incorporates bandspread tuning at the lower end of the m.w. band (195-215 metres). Two new mains-operated transistor record players (RP231 and RP232) are being shown.

Radio Gramophone Development Co. Ltd., Sidcup, Kent.

RADIO & ALLIED INDUSTRIES (14, X11)

A number of 19- and 23-in television receivers are on display under the brand names Sobell and McMichael. All of these are dual-standard and two of the Sobell receivers have v.h.f. sound radio facilities. There is a variety of sound receivers and radiograms on display, ranging from the Sobell World Ranger three-waveband portable to the McMichael Model 207 six-watt stereogram. The Mark 2 version of the World Ranger receiver has been specially made to double as a fitted car radio, being fitted with a coupling transformer to match the car aerial.

Radio & Allied (Holdings) Ltd., Langley Park, Slough, Bucks.

RADIO & TELEVISION SERVICES (62)

A comprehensive range of electrical, radio and television components is being shown. In addition to being suppliers of replacement parts, and service information, for the Pye, Ekco, Pam, Ferranti and Invicta ranges of receivers, R.T.S. act as wholesalers for u.h.f. and car radio aerials and accessories, diamond and sapphire styli, recording tapes and test equipment.

Radio & Television Services Ltd., P.O. Box 11, Cambridge.

REDIFFUSION VISION (57)

The two main facets of Rediffusion's activities are demonstrated—its wired vision and sound distribution system and its current range of "aerial" receivers for sale or rental. The ad-

vantages of the h.f. (5-10 Mc/s) distribution system, including the use of simplified receivers, are emphasized.

Rediffusion Vision Service Ltd., Fullers Way South, Chessington, Surrey.

REGENTONE (12)

A new stereo radiogram (SRG25) covering the l.w., m.w. and s.w. bands as well as the v.h.f. band and fitted with two 10-in elliptical speakers is on show. It has an output of 3W per channel. The cocktail-style cabinet is 4ft 5in wide. Two new mains-operated transistor record players, the TP431, which is in a moulded polypropylene case, and the TP432, in a wooden cabinet, are introduced. Regentone are also showing a new dual-standard television set which is available with 19-in (model 401) or 23-in (model 501) screen. The 1963/4 range of transistor portables—the BT20, 21, 22 and 23—all of which cover the medium- and long-wave bands are being shown.

Regentone Radio and Television Ltd., Regent Works, Sidcup, Kent.

REVELATION

(see Wood & Sons stand 48)

ROBERTS RADIO (40)

Two quality transistor portables are being shown. The R300 covers the long- and medium-wave bands and has an output of 500 milliwatts. Six transistors and three diodes are used in a superhet circuit. An extra transistor is used in the a.f. stage of the R500 to provide an output of 1 watt. This model is a three-waveband receiver, covering 16-50, 183-570 and 1120-2000 metres. A ferrite-rod aerial, with provision for connecting to an external car type aerial, is fitted to both receivers.

Roberts' Radio Co. Ltd., Molesey Avenue, West Molesey, Surrey.

ROYAL NAVY (7)

Exhibits feature electronic equipment fitted in ships and aircraft of the Royal Navy or used for training personnel. Among them is a computer which forms part of the Action Data Automation system now coming into service in H.M. ships. Being demonstrated is a marine radar simulator used for training navigation officers and ratings, and a typical navigational radar. A feature of the Navy's stand is a 44-ft long model of H.M.S. *Hampshire*, the guided missile destroyer.

Ministry of Defence, Whitehall, London, S.W.1.

SLINGSBY (46)

Aluminium ladders and tubular-steel appliance trucks are shown. This stand should be of interest to the aerial erector and the television-delivery man and service engineer. Features of the roof ladder on show

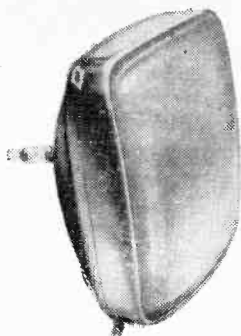

Mazda "Rimguard" c.r. tube is shown on the Thorn-AEI stand.



Model R500 transistor portable from Roberts Radio.

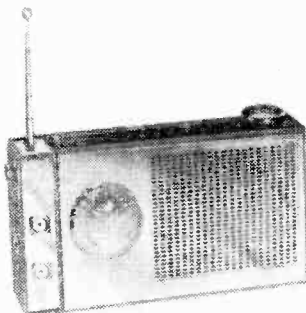

Sobell World Ranger three-waveband transistor portable is shown by Radio & Allied Industries.



This Revelation Model T20 three-waveband transistor portable can be seen on stand 48 (W. Wood & Son).

include rubber-padded pressure plates to minimize tile damage.

H. C. Slingsby Ltd., Kingsway, London, W.C.2.

SOBELL

(see Radio and Allied Industries stand 14)

SOUND

(see Tape Recorders stand 65)

STELLA (69, X7)

Some 20 different products are featured on the Stella stand. These include transistor and mains radios, radiograms, television receivers, and a new mains record player and four Peto Scott television receivers. Five radiograms are featured, representing both mono and stereo record playing equipment and radio receiving units with or without v.h.f. One of the two new radiograms, the ST 320, has been designed for the flat dweller and is only 13in deep at floor level and only 9in deep at the top. This has been achieved by mounting the player unit on a drop-front flap which is retained in a vertical position when not in use. Of the eight television receivers, five have 19-in screens and three, 23-in. A choice is provided in both the 19- and 23-in models of either front- or side-mounted controls and loudspeakers.

Stella Radio & Television Company Ltd., Astra House, 121 Shaftesbury Avenue, London, W.C.2.

TAPE RECORDERS (ELECTRONICS) (65)

The Sound International range of tape recorders, comprising five models, is being shown this year, along with radiograms, record players and transistor radios, all of which are on show for the first time. The Model TRE 14 is the most inexpensive of the tape recorders and comprises a single-speed, twin-track machine. The senior instrument in the range, the Model TRE 40, is a three-speed, four-track machine whose features include parallel track recording, monitoring through the loudspeaker, full mixing and superimposition facilities, base and treble controls, and can be used as an independent amplifier.

Tape Recorders (Electronics) Ltd., 105-113 Lawrence Road, Tottenham, London, N.15.

TERRITORIAL ARMY (26A)

An information and recruiting centre has been set up in a caravan. Although concerned with recruitment into the Territorial Army in general there is a bias towards the field of communications.

Territorial Army, Duke of York's H.Q., London, S.W.3.

THORN-AEI (64, X14)

Brimar and Mazda valves, c.p. tubes and semiconductor, and publications covering their applications are featured. The centre of technical interest is the two safety monopanels Rimguard picture tubes introduced

by Mazda. They are rendered safe from violent implosion by a metal stress-distributing rim cemented to the glass face and do not require a separate implosion screen, thereby reducing halation and giving increased picture quality. Both 19-in and 23-in screens (types CME 1905 and 2305 respectively) are available. A new range of 11 germanium semiconductors for audio driver and output stages have been introduced together with several new silicon diode devices for use in television receivers.

In the "setmaker reception centre" (X14) where admission is by ticket only, several of the latest circuit developments from the Thorn-AEI Applications Laboratory are featured. Among them is the "Kickback Field Timebase" featuring Mazda 30PL14 valve.

Thorn-AEI Radio Valves & Tubes Ltd., 155 Charing Cross Road, London, W.C.2.

ULTRA (41, X4)

Television receivers, transistor portables, radiograms, record players and tape recorders are shown. Their first all-transistor stereo a.m./f.m. radiogram, the Transistogram 6312, being shown for the first time this year, employs 20 transistors and eight diodes to provide 2½ watts output per channel. The radio section of the 6312 covers the long-, medium- and short-wave bands and 87.5-101 Mc/s in the v.h.f. band. The gramophone unit comprises a Garrard Auto Slim 11-inch turntable with a Ronette cartridge.

Ultra Radio and Television Ltd., Television House, Eastcote, Ruislip, Middx.

WIRELESS FOR THE BEDRIDDEN (79)

The "Wireless for the Bedridden" Society relies entirely upon voluntary contributions to provide free radio facilities to needy bedridden, house-bound and aged invalids. Mains or

transistor receivers (purchased through local dealers) or relay services, are installed and maintained without cost to the recipient—the licence also being provided where necessary. Well over 10,500 installations have so far been made. Television facilities are also supplied to Voluntary Old People's Homes, etc. Space for this stand has been given by the show organizers.

"Wireless for the Bedridden" Society, 20 Wimpole Street, London, W.1.

WOOD & SON (48)

The latest range of audio products made by the electronics division of the Revelation luggage firm are characterized by cabinets moulded in Boltaron thermoplastic which has a high resistance to impact and abrasion. Tape recorders, transistor portables and record players are shown.

W. Wood & Son, Kelvin Works, Power Road, Chiswick, London, W.4.

ICI ON PARLE LE DOUBLETALK

FOREIGN VISITOR'S GUIDE TO EARLS COURT

By "VECTOR"

TO residents on the Continent, and even further afield, an annual excursion to the National Television and Radio Exhibition is rapidly becoming one of the major events in the overseas sportsman's calendar, combining as it does all the healthy excitements of a marathon obstacle race and a penitent's pilgrimage (the latter rising to its climax at the prospect of a week in Britain on minced beef and sog, with rhubarb and custard to follow).

This year's event promises to outstrip all its predecessors, for whilst the main hazards along the cross-channel routes will remain in the capable hands of British Railways, ably assisted by H.M. Customs and Excise, it is understood that negotiations are afoot to tear up all the runways at southern airports, thereby affording the visitor a fascinating detour to Wick and the exhilarating prospect of an all-night journey in the corridor of a slow train to Euston.

But it is not so much the journey with which we are concerned, as the Mecca at the end of it. In order that the foreign visitor may find it even better to arrive than to travel hopefully, the following hints have been compiled; these, if followed, should ensure that every overseas guest gets what he is asking for.

A "must" in the intending visitor's travelling kit is a small device called a *Dia-faed*. This is a deaf-aid in reverse. The more sophisti-

cated models employ a microphone input to a -12 dB transistorized attenuator, which in turn feeds an earpiece, but simpler versions are available which consist of wads of cotton wool stuffed in the aural meatuses (or lugholes, as the British *patois* has it). The constant use of either instrument will greatly enhance the visitor's comfort, as the British, to a man, are convinced that anyone with a foreign accent is *ipso facto*, stone deaf and accordingly conduct any conversation with him at a level of 12 dB up, and in tones otherwise reserved for imbeciles.

The tourist would be well advised to be constantly on his guard, never taking even the most insignificant detail at its face value. Consider, as an instance, the apparently innocuous title of his goal, The TV & Radio Exhibition. This, to the earnest overseas student, carries with it the clear implication that in Britain television is not a form of radio communication at all. Does it, he is tempted to wonder, function by means of suction and mirrors? Alay your fears, brother. No matter what the British may try to make you think, their television system uses lines just the same as yours, only not so many of them.

Then again, he will find that many Britons call the exhibition "Radiolympia." This is a telescoping of the two words "Radio" and "Olympia," the latter being a place where exhibi-

tions are held, but not the Radio Exhibition. That is precisely why the British speak of Radiolympia. It is just another example of perfidious Albion at work, bedevilling the hapless foreigner, who, if he incautiously books to Olympia on the underground will be told he really wants Kensington and will surely find himself stranded in a savage locality called Earls Court, from which an elongated slug (laughingly called a train) runs to the Olympia station only when there is an R in the month. The more intrepid may, by engaging native bearers, safari to Olympia, but this is all rather futile as the exhibition is at Earls Court anyway.

The Radio Show (another alias) is held in a massive architectural monstrosity somewhat resembling an airship hangar gone to seed. This year the stands are to be confined to the ground floor, in order to avoid the distressing mishap of 1962 when two unwary visitors climbed to an upper gallery without donning oxygen masks, perishing miserably and creating an international incident simultaneously. It is rumoured that if this diminution of exhibits proves a success and that if the trend towards microelectronics continues, next year's show will be held in a telephone kiosk.

It is only to be expected that age-old British institutions should be steeped in tradition, and the Radio

Show is no exception. One of the more fascinating of these is the Electrician's Strike, which takes place about two days before opening day, thereby affording the privileged spectator the sight of anguished technicians struggling by candlelight to get their wares in some semblance of order against the deadline.

On entering the exhibition, one might well be daunted at the vista of avenues of stands. There is no occasion for despondency. All the radios look and sound alike, and the television pictures, although differing in content according to which of the three channels is being used, are only otherwise distinguishable in that the high-quality channel is perhaps slightly inferior to the other two. In short, when you have seen one you have seen the lot.

Nevertheless, if conscience demands that a ritual sampling of stands be undertaken, the foreign visitor will at first be gratified to find that certain of the more enlightened manufacturers have provided for aching feet and dry throats by building little oases furnished with deep arm chairs and a working model of a bar, the latter presided over by an accommodating barmaid in 3-D.

Alas! No Eden is without its serpent, and our foreign friend may find violent hands laid upon him by a brutal and licentious sales staff who will cast him into outer darkness with expedition, in default of his providing the requisite open sesame.

The wise traveller will have come already provided against this embarrassing contingency by arming himself with a supply of visiting

cards engraved with any name but his own, and the legend "CHIEF BUYER" in bold print, followed by the name of any well-known Continental buying organization. He will find, on production of one of these that even visiting Royalty will be brushed aside in the rush to ensure his creature comfort. It all goes to prove, if proof be needed, that at heart the British are a simple folk, with one simple requirement. Money.

"A camel," runs the proverb, "is a horse designed by a committee." In Britain nothing is ever done until a committee has brooded over the matter for years, and so the output of camels is prodigious. Two resident camels, the B.B.C. and I.T.A., have the two biggest stands in the show, and to observe their audience-wooing techniques at Earls Court is one of life's more moving experiences.

The foreign guest, while observing that both broadcasting organizations are wholly dedicated to the service of the Great British Public in that they both peddle similar brands of American corn, may be forgiven for wondering where the difference between them lies. It is absolutely fundamental. Whereas the I.T.A. permits advertisements on condition that they are paid for, those appearing on B.B.C. screen are made entirely without charge.

Another difference is that the I.T.A. is not permitted to set up sound broadcasting stations, which are the monopoly of the B.B.C. At least, the B.B.C. thought so until a while back, when someone played a rather horrid trick by transmitting from ships lying outside the three-

mile limit. As far as can be ascertained there is no foundation for the rumour that the B.B.C. is negotiating the purchase of a submarine.

One of the great mysteries of the Radio Show is intimately connected with foreign visitors. The British manufacturers, who appreciate to the full the value of appealing to the overseas customer's cheque-book in its own tongue, ensure that each stand carries a full complement of multilingual experts. They are certainly there all right first thing in the morning, for a ceremonial counting is carried out on every stand. Then the doors open and—presto!—every single one disappears into thin air, leaving the foreigner to cope with explanations in Old Etonian, a language which is not widely understood on the Continent. Or in this country either, for that matter.

One final word of warning. The foreign customer, assuming that he has managed to place an order, should take the utmost care to ensure that what he thinks he is getting, and what he is going to get, is one and the same. Remember that a nation which calls capacitors "condensers" because they do not condense, and refers to frequency changers as "first detectors" because they do not detect—a nation like that, I suggest, is capable of anything. Let us hope, my friend, that having ordered 500 gross of transistors—those little specks of semiconductor—you do not arrive home to find the local quayside submerged under a mountain of tiny portable radios, all squawking "Rule Britannia."

H. F. PREDICTIONS — SEPTEMBER

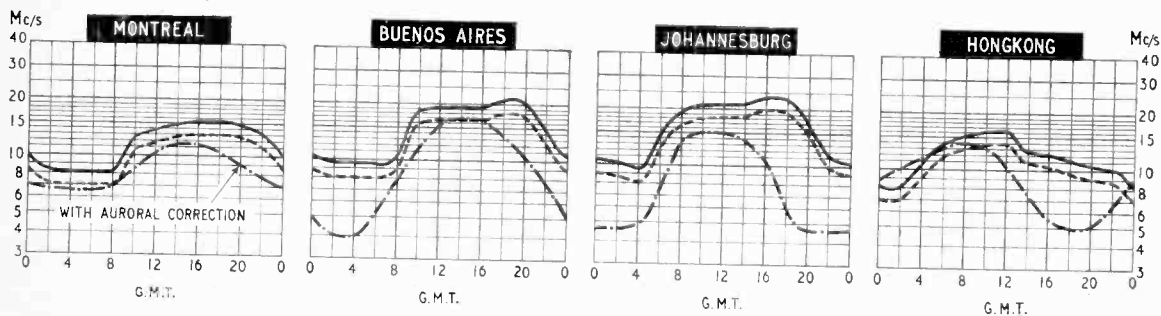

The prediction curves show the median standard MUF, optimum traffic frequency and the lowest usable frequency (LUF) for reception in this country. Unlike the standard MUF, the LUF is closely dependent upon such factors as transmitter power, aerials, and the type of modulation. The LUF curves shown are those drawn by Cable and Wireless Ltd. for commercial telegraphy and assume the use of transmitter power of several kilowatts and rhombic aerials.

The LUF is also a function of the local noise level. Thus, given identical equipment at the two ends of

the circuit, the values of LUF for the two directions may differ. During this month, considerably higher noise levels would be expected at night in Hongkong than in London. Thus, the LUF for the London-Hongkong path might be expected to be some 4Mc/s higher for the period 1400-1800 GMT.

WORLD OF WIRELESS

Co-ordinating Research

WITH the object of "encouraging and co-ordinating research in the field of radio and electronic science" the National Electronics Research Council has been set up under the chairmanship of Admiral of the Fleet Earl Mountbatten. N.E.R.C. is a joint Government-industry enterprise and the governing body consists of the permanent secretaries and other representatives of all the interested Government departments, representatives of universities and the chairman or other nominee of the twelve largest electronics manufacturing companies.*

N.E.R.C. is not a research organization but a central co-ordinating body which plans to highlight gaps in research, show where additional effort is needed, suggest priorities and prevent unnecessary duplication of research. It aims to ensure that new ideas arising from defence projects which are released from the "Secret List" and those arising from the more speculative research in universities, are made available for adoption and exploitation by industry with the minimum of delay.

The retrieval of information from the vast quantity of published material is to be undertaken through a central information service. The Council will also keep under review the granting of scholarships and awards for electronics research.

In a nutshell; the Council aims to marry the needs of the Government in the defence field with the enterprise of the radio and electronics industry.

*The following were nominated by the Conference of the Electronics industry—Sir Leon Bagrit (Elliott-Automation), M. Clark (Plessey), S. S. Eriks (Mullard), S. Z. de Ferranti (Ferranti), O. W. Humphreys (G.E.C.), Sir Joseph Lockwood (E.M.I.), G. S. C. Lucas (A.E.I.), Lord Nelson of Stafford (English Electric), Sir Gordon Radley (Marconi), C. O. Stanley (Pye), Sir Jules Thorn (Thorn Electrical) and F. C. Wright (S.T.C.).

World Space Communications

AGREEMENTS were reached at the 18-nation conference held in Washington at the end of July for the provision of a global communication satellite system. These provide that the design, development, construction and establishment of the satellites themselves and the ground installations for their control, will be a co-operative international enterprise. The telecommunications ground stations will be owned by the countries, or groups of countries in which they are located. Control will be exercised by a 12-man international committee, on which the U.S.A., Canada, Australia, Japan, the U.K. and seven other European countries will be represented.

The United States Communication Satellite Corporation (Comsat) will act as the manager for the space system, pursuant to the general policies of the international committee. The U.K. will contribute about £6M to the system representing 8.4% of the total, compared with 6.1% each from France and Germany, 3.75% for Canada, 2.75% from Australia and 61% from the U.S.A.

Licence for Pay Television

THE first licence for a subscription television service in this country has been awarded to Telemeter Programmes Ltd., a subsidiary of British Telemeter Home Viewing. It permits the company to operate pay television for a trial period of up to three years in South West London. The trials must start by September 1965 and the company will be permitted to provide up to 50 hours of programmes a week. The trials will be conducted in the Wimbledon, Mitcham, Merton and Morden areas, where it is hoped to link between 2,500 and 3,000 subscribers to the service.

Higher Priority for the Industry

WHEREAS in 1955 U.K. manufacturers were contributing 10% to the total world exports in electronic equipment, in 1963 the U.K. share was only 1.5%. These figures were given by The Rt. Hon. Edward Heath, M.B.E., Secretary for Industry, Trade and Regional Development and President of the Board of Trade, when addressing the Radio Industries Club. He added: "This shows how big the task is for the electronic industry . . . I want to see the country giving a much higher priority to the industry and all connected with it. Not only the production and manufacture, but also the scientific research and development."

British Association Meeting

SINCE mentioning last month one or two papers from the preliminary programme of the British Association meeting at Southampton (26th Aug.-2nd Sept.) we have received the full programme in which there are many other papers which may be of interest to readers. J. A. Ratcliffe's address on "The sun and the ionosphere" on 28th August is followed by two others by authors from the D.S.I.R. Radio Research Station—Dr. D. A. Bryant on "Particles from the sun" and Dr. J. W. King on "The top of the ionosphere". On the 27th

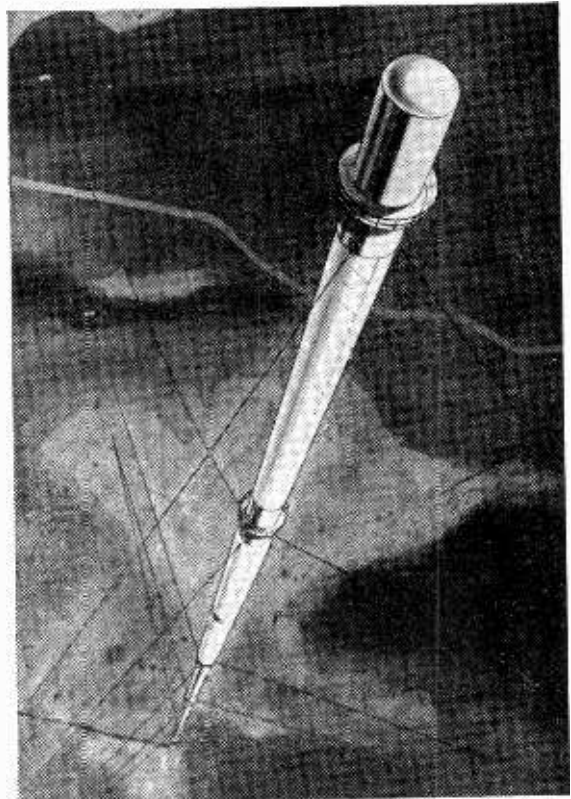

An eagle's-eye view.—A sketch of the B.B.C./I.T.A. mast to be erected by B. I. Construction Co. at the Winter Hill station of the I.T.A. It will be 1000 ft tall and accommodate four u.h.f. and two v.h.f. television aeriels and a Band II aerial in the glass-fibre covered topmast. Similar cylindrical masts are to be erected at Emley Moor, Yorks, and Belmont, Lincs.

I. Macwhirter, of Thorn-AEI Radio Valves and Tubes, deals with "Recent developments in colour television". S. Ratcliffe (Royal Radar Establishment) will give a paper on "Computers and air traffic control" on 1st September. Prof. G. D. Sims, of Southampton University, introduces the session on the 1st covering methods of electrical communication during which W. J. Bray (Post Office Research Station) will deal with communication satellite systems and Dr. W. A. Gambling (Southampton University) optical communications. During the Meeting an electronics exhibition is being staged in the laboratories of the University's Department of Electronics.

International Standardization.—As a result of the recent meeting of the International Electrotechnical Commission in Aix-les-Bains, France, a number of draft recommendations for international standards will be circulated to national committees for approval. The new chairman of the British National Committee is S. E. Goodall, of A.E.I. (Woolwich). Among the draft recommendations is one concerned with graphical symbols for inductors, transformers, electronic tubes, valves and rectifiers. Another covers characteristics of sound-system amplifiers. One of three new technical committees set up by I.E.C. will deal with the reliability of electronic components and equipment.

Components and Materials.—During next year's Components Exhibition at Olympia (18th-21st May) a joint conference on components and materials used in electronic engineering is to be held by the I.E.E., the I.E.R.E. and the U.K. section of the I.E.E.E. The conference, which will be from 17th-21st May, will cover recent developments in active and passive components (including integrated circuits) and in the materials of which they are made. Thermionic and cold-cathode valves will not be included, neither will applications except in so far as they influence component design. Further particulars are available from the I.E.E., Savoy Place, London, W.C.2.

Stockholm Electronics Show.—More than 50 British firms will be taking part in the British Electronic Component and Instrument Exhibition to be held in Stockholm from 13th to 16th October this year. This exhibition is the largest of the series held in Stockholm over the last 15 years under the auspices of the Radio and Electronic Component Manufacturers' Federation.

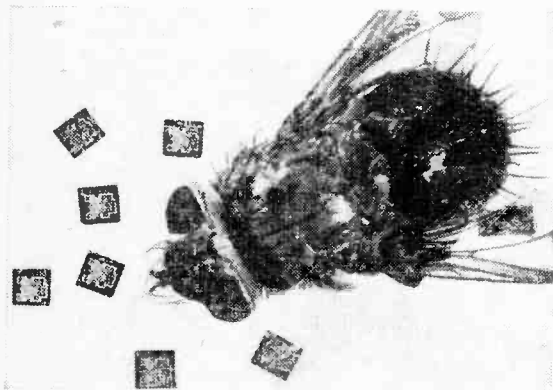

Each integrated circuit in which this housefly is simulating interest contains 22 transistors and 6 resistors. The chips, made by Sylvania Electric Products Inc., measure 0.05 x 0.05 x 0.006 in and are designed for missile and aircraft guidance systems.

The Postmaster-General has announced that the **Post Office Research Station**, which has been at Dollis Hill, London, since 1921, is to be moved in four or five years' time to the vicinity of Martlesham, Suffolk. The Research Station with its outstations at Eastcote, Middx., Backwell, Som., and Castleton, Mon., has a staff of nearly 1,500 of which about one third are scientists or engineers.

A **commemorative stamp** is to be issued later this year by the United States Government to mark the 50th anniversary of the founding of the American Radio Relay League in 1914. The A.R.R.L. is preparing a "first-day cover" envelope. Details will be available from the League (225 Main Street, Newington, Conn.) in September.

International Amateur Radio.—Throughout the 48 hours of the second international amateur radio convention being held in Geneva on 5th and 6th September, the station of the International Amateur Radio Club (4U1ITU) will be transmitting on all amateur bands. The theme of the convention is "Future of Amateur Radio—Ham-Tech-Aid."

Broadcast Receiving Licences.—In the first half of 1964, the number of combined television and sound receiving licences increased by nearly quarter of a million to 13,010,335. Sound only licences, which include those issued for car radio, dropped by 129,000 to 2,962,969, whilst the number of car radio licences rose by 23,500 to 592,349.

"**Colour Television by Wire**" is the subject of the first meeting of the 1964/5 programme of the Television Society. The paper, by E. J. Gargini, of Rediffusion Research, will be read on 18th September at 7.0 at the I.T.A. headquarters, 70 Brompton Road, London, S.W.3.

Receiver Styling.—The eighth international exhibition of cabinet styling accessories is being held in the Hotel Russell, London, W.C.1, from 29th September to 1st October. Organized by Radio Industry Exhibitions on behalf of the British Radio Equipment Manufacturers' Association it will be open each afternoon from 2.0 to 6.30 to representatives of industry on the presentation of a business card.

VASCA Officers.—The new chairman of the Electronic Valve and Semi-Conductor Manufacturers' Association is C. A. W. Harmer, of Pye Ltd., who is also chairman of the general management committee. R. H. Deighton (English Electric Valve Co.) is now chairman of the committee concerned with industrial valves and tubes, and Dr. E. G. James (G.E.C.), chairman of the semiconductor devices management committee.

"**Current Papers**" is the title of a new monthly broadsheet being issued by the I.E.E. "to help the electrical and electronics engineer to learn at a glance what recent papers relevant to his subject are available." It lists titles of articles which have appeared in some 150 British and overseas periodicals during the previous month. Each issue will include 600-700 references, and the annual subscription is £1.

How Colour Television Works.—"A plain man's guide to colour television" is the title of a recent booklet prepared by Associated TeleVision Ltd., 17 Gt. Cumberland Place, London, W.1. Compiled by T. C. Macnamara (Technical Counsellor of A.T.V.), it describes—in question and answer form—how colour television works, after briefly touching on the principles of monochrome receivers.

Electronics Advisory Board.—The Electrical Research Association has announced that the following people have accepted invitations to serve as members of the Electronics Advisory Board: Dr. L. G. Brazier (B.I.C.C.); R. J. Halsey (G.P.O. Research Station); Dr. G. L. Hutchinson (R.R.E.); B. N. MacLarty (Marconi); and D. S. Ridler (S.T.C.). The existing members of the Board, under the chairmanship of Sir Harold Bishop, are: E. Alexander (A.E.I.); R. J. Clayton (G.E.C. Electronics); W. Gregson (Ferranti); P. F. Mariner (Elliott); and Prof. C. W. Oatley (Cambridge University).

The Institute of Sound and Vibration Research is holding a three-day course on **practical noise control**, covering acoustics, noise measurement, subjective assessment and technical principles of noise control, at Southampton University from 16th September.

Semiconductor Rectifier Diodes.—Guidance on the minimum data to be quoted by a manufacturer of semiconductor devices in describing his products for general sale is given in B.S. 3771 "Recommendations on semiconductor rectifier diodes (mono-crystalline)." This publication is divided into three main sections covering essential ratings and characteristics; methods of measurement of electrical characteristics; and assessment of working conditions. Copies of B.S. 3771 may be obtained, price 10s (plus postage), from the B.S.I. Sales Branch, 2 Park Street, London, W.1.

Isle of Man TV.—Answering a question in the House recently as to whether he will grant a licence for the transmission of commercial television programmes in the Isle of Man on similar power to commercial stations operating in the United Kingdom, the Postmaster-General, Mr. Bevins, replied: "The I.T.A. is building in the island a satellite station which will broadcast Border Television programmes on Channel 8. The Authority hopes to have the station in service in the first half of next year." E.M.I. Electronics Ltd. has received an order from the I.T.A. for the aerial which will be horizontally polarized and have an e.r.p. of 9kW.

A conference on **solid state physics** is being organized by the Institute of Physics & Physical Society for 5th to 8th January next year at the H. H. Wills Physics Laboratory, University of Bristol. Provisional programmes and application forms are available from the organizers at 47 Belgrave Square, London, S.W.1.

New Cable Repair Ship.—C.S. *Enterprise*, a 4,300-ton (gross) repair ship is the latest addition to the cables fleet of Cable and Wireless Ltd. She was built at a cost of over £1,250,000 and is fully equipped for carrying out repairs to all types of deep-sea cable, including coaxial cable with submerged repeaters. C.S. *Enterprise* is the fifth Cable and Wireless ship so equipped and will be based in the Far East.

PERSONALITIES

Captain C. F. Booth, C.B.E., M.I.E.E., who recently retired from the post of deputy engineer-in-chief at the Post Office, has been appointed communications consultant to Plessey-U.K. Ltd. Of Captain Booth's 40 years in the Post Office he spent 25 at the Dollis Hill Re-



Captain C. F. Booth

search Station. His last major assignment was responsibility for the design and installation of the Goonhilly Down station for satellite communications.

H. G. Lillicrap, B.Sc., A.M.I.E.E., is the new director of the Radio Services Department at the Post Office in succession to **A. Wolstencroft, C.B.**, who, as announced in the July

issue, has become deputy director general. Mr. Lillicrap was in the G.E.C. Research Laboratories at Wembley before joining the Post Office as a probationary assistant engineer in 1936. He then spent nearly ten years at the Post Office Research Station on the design of transmitters and receivers and in 1947 moved to the Radio Branch at Headquarters where he was concerned mainly with frequency allocations. In 1951 he went into the Overseas Telecommunications Department (now the External Telecommunications Executive) of which he became deputy director in 1958.

D. L. Phillips, M.M., B.Sc., A.M.I.E.R.E., general manager of Mills & Rockleys (Electronics) Ltd., of Coventry, since 1960, has become managing director, in place of **H. G. Ellinger** who is now chairman. Mr. Phillips was works manager of Technograph Electronic Products Ltd. before joining the Mills & Rockleys group as consultant in 1958. During the war he served in the R.A.F. as a technical signals officer and immediately prior to joining Technograph was with Plessey.

William Logan, sales director of Avo and a director of Taylor Electrical Instruments (both members of the Metal Industries Group), is the new president of the Scientific Instrument Manufacturers' Association.

Mr. Logan, who has served on the council of S.I.M.A. since 1949, joined Avo as contracts manager in 1952. He served with R.E.M.E. during the war, retiring with the rank of major, and spent several years on radar development at, what is now the Royal Radar Establishment, Malvern.



William Logan

K. A. Russell, B.Sc., A.M.I.E.E., chief engineer of the British Relay Group since 1947, has been elected to the board. Mr. Russell graduated at Leeds University in 1941 and joined the R.A.F., in which he was a signals/radar instructor at Yatesbury for four years. In 1946 he joined British Relay Wireless and took charge of research. He was president of the Society of Relay Engineers for 1952/54.

Air Comdre. Anthony G. Powell, A.M.I.E.E., director of technical policy at the Air Ministry since March 1962, has been appointed to the new Ministry of Defence post of director of radio (air). After passing out of the R.A.F. College, Cranwell, as a pilot in 1932, he later took a course at the Electrical and Wireless School, Cranwell. He held a number of senior signals appointments in the Service during the war following which he commanded No. 70 Radar Wing in Scotland and Northern England. Air Comdre. Powell was from 1955-57 chief of the Electronics Branch at Supreme Headquarters Allied Powers Europe and in 1958 went to Signals Command H.Q. as senior air staff officer.

Paul Spring, A.M.I.E.E., who joined Grundig (Great Britain) Ltd., on its formation in 1952 and since 1955 has been chief engineer, has been appointed to the board as technical director. Mr. Spring was with



Paul Spring

Thermionic Products working on the design of tape recorders and dictating machines prior to joining Grundig. He is a member of the dictating machines committee of the British Standards Institution.

Consequent upon the death of Mr. Perring-Thoms, recorded below, **C. E. M. Hardie** has been appointed chairman of Radio Rentals Ltd., which has become the holding company of the Group and a new operating company Radio Rentals (U.K.) Ltd. has been formed to conduct the rental business. **J. C. O'Regan** has become managing director of the new company and **W. W. Warnes**, who is managing director of Baird Television Ltd. the group's manufacturing company, has been elected to the board of the holding company. When the acquisition of Rentaset Ltd. has been completed **J. W. C. Robinson**, chairman of Rentaset, is to become managing director of the holding company, Radio Rentals Ltd., and group chief executive.

Captain Robert A. Villiers, C.B.E., A.M.I.E.E., R.N. (Retd.), director of the Scientific Instrument Manufacturers' Association for the past five years, has become director (a new post) of the Electronic Engineering



Captain Robert Villiers

Association. Capt. Villiers, who at one time commanded the Admiralty Underwater Countermeasures & Weapons Establishment at Havant, has been acting as secretary of the Conference of the Electronics Industry since it was set up a year ago.

V. Pereira-Mendoza, M.Sc.Tech., M.I.E.E., head of the department of electrical engineering at the Borough Polytechnic, London, has been appointed vice-principal of the Polytechnic. Mr. Mendoza, who is 57, is a graduate of Manchester University and has held his present position for the past seven years. He served with the Royal Corps of Signals during the war and attained the rank of major.

OBITUARY

Albert Beaumont Wood, O.B.E., D.Sc., who died on 19th July, aged 70, was an acknowledged authority on electroacoustics and in particular on underwater sound. After graduating from Manchester under Rutherford, Dr. Wood joined the Board of Invention and Research in 1915 to work on hydrophones and other anti-submarine devices and in 1921 joined the Admiralty Research Laboratory at Teddington, of which he became Superintendent in 1943. His text-book "Sound," first published in 1930, is still one of the fundamental source books on acoustics.

Percy Perring-Thoms, founder, chairman and managing director of Radio Rentals Ltd., died on 31st July, aged 64. He started a radio retail business in Brighton in 1930 and from this grew the present radio

H. F. Humphreys, who was engineer-in-charge at several B.B.C. stations, including Droitwich, before going overseas, has been appointed chief engineer of Radio Uganda. He was lent by the B.B.C. to the Hellenic National Broadcasting Institute as technical adviser over the period 1948-54 and was largely responsible for the post-war development of broadcasting in Greece.

OUR AUTHORS

K. E. Hancock, the second of whose series of articles on microwave techniques appears in this issue, has been with the Canadian Marconi Company since 1962. He joined as a senior development engineer and is now senior project engineer in charge of the microwave components section of the telecommunications department. Mr. Hancock was educated at the South East London Technical Institute and joined the R.A.F., in which he was commissioned and worked mainly on air radar. He left the R.A.F. in 1960 and joined W. H. Sanders Ltd., at Stevenage, where he was deputy head of the microwave development group when he left to go to Canada.

M. F. Radford, M.A., the first part of whose article on logarithmic dipole aerials appears on page 424, has been chief of the aerial research section in Marconi's Research Division since 1960. He read mathematics at St. John's College, Cambridge, and also studied electrical engineering before joining the Marconi Company as a graduate apprentice in 1953. A year later he went into the Research Division to work on microwave aerial scanning systems. He is 35.

and television rental organization which a few years ago acquired the trade name Baird. To help perpetuate the name of the television pioneer Mr. Perring-Thoms initiated the Baird Travelling Scholarship which is awarded annually by the Television Society.

G. T. Syminton, engineer-in-charge (transmitters) in the Uganda Broadcasting Service, died in Mulago Hospital, Kampala, on 6th July, aged 44. As a wartime officer in the Royal Corps of Signals Mr. Syminton was intimately concerned with the installation and operation of the high-power transmitters at Radio Ceylon. He joined the Marconi Company after the war and first went to Uganda in connection with the establishment of a Police Radio Service in 1954. He later transferred to the Uganda Broadcasting Service.

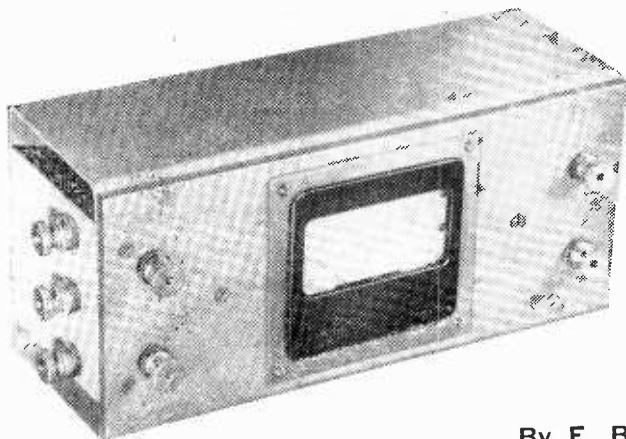

TRANSISTOR AUDIO-FREQUENCY PHASEMETER

By F. BUTLER, O.B.E., B.Sc., M.I.E.E., M.I.E.R.E.

A PHASEMETER of this type has a wide range of applications. It can be used for phasing stereo sound equipment, for checking wide-band phase shifters in single sideband transmitters, for testing filters, phase equalizers, feedback amplifiers and networks as well as for routine checks of loudspeakers, microphones and other transducers. With simple accessories it can be used to measure the velocity of sound in air or other media.

One method of measuring the relative phase of two sinusoidal signals is to apply each one to a limiter or clipping amplifier so that rectangular output waveforms are produced with steep leading and trailing edges. Phase difference between the original sinusoids is then represented by the time difference between corresponding points on the two waveforms, e.g. the instants of zero-crossing. To measure this time difference in analogue form as a fraction of the duration of one cycle of the input signal the two square waves may be coupled to the inputs of a flip-flop or toggle in which the state is changed by one of the square waves and then changed back again by the other. One flip-flop output is a rectangular wave in which the mark-to-space ratio depends on the relative timing of the switching step-voltages or pulses. The output of the other half of the flip-flop is the inverse or complement of the first. When one is turned off the other is hard on.

In the case of transistor flip-flops the collector voltage of the "on" transistor is its saturation voltage, normally a fraction of one volt; that of the "off" transistor is almost equal to the supply voltage. If a high-resistance d.c. voltmeter is connected across one output of the flip-flop, while this is being switched, the voltage will alternate between the two extreme limits and the average meter reading will indicate the proportion of the total time during which this particular transistor has been held "on." For example, assuming that the transistor saturation voltage is 1 V and that the power supply is 12 V, then a meter reading of 6.5 V or $\frac{1}{2}(1+12)$ V would show that the flip-flop had been on for half the time. This corresponds to an exact square-wave output and shows that the phase difference between the original sinusoids must have been 180 degrees.

The principle of a phase-measuring circuit using this technique has been described by J. R. Wood-

bury¹. The instrument to be described is based on Woodbury's arrangement, modified to give greater sensitivity, higher input impedance and better performance at low audio frequencies. It also makes use of a flip-flop stage which is a standard item of commercial equipment, available cheaply from several manufacturers. The labour of designing, assembling and wiring these is no longer worth while from the user's point of view.

Another phasemeter, using thermionic valves, but working on basically similar principles, has been described by T. E. Reamer². It employs six double triodes and a gated-beam dual-grid tube, covers the frequency range 20 c/s to 50 kc/s, accepts sine, sawtooth and rectangular input waveforms (without adjustment), between 0.5 and 60 V r.m.s. and indicates over phase ranges of ± 180 degrees with an error not exceeding ± 3 degrees up to 20 kc/s, rising to ± 7 degrees at 50 kc/s. Reamer's paper is a model of lucidity and, besides going into great detail on the design of the actual instrument, contains an excellent survey of various phase-measuring techniques, complete with a useful bibliography. As it stands, the input requirements of Reamer's circuit make it unsuitable for use with transistor equipment or other low-level signal sources. Twin-channel pre-amplifiers of approximately equal gain and exactly equal phase shift (time delay), would be necessary to increase the sensitivity by a factor of say 10 to 100.

By modest relaxations of the specification it is possible to produce a completely transistorized unit of comparable performance. The chief limitation is in the acceptable dynamic range of input levels. Provided that the inputs are kept within ± 6 dB of the optimum value, the design can be simplified without degrading the performance in other ways.

Design Requirements:—In a general-purpose phasemeter, ease of operation, absence of preset controls or adjustments, wide frequency range, unambiguous phase indications, small size and weight, reliability and circuit simplicity are all considerations which must be balanced against the requirement for high accuracy. For most purposes, errors of ± 2 degrees ± 2 per cent of the indicated phase angle are acceptable. This performance is achievable over

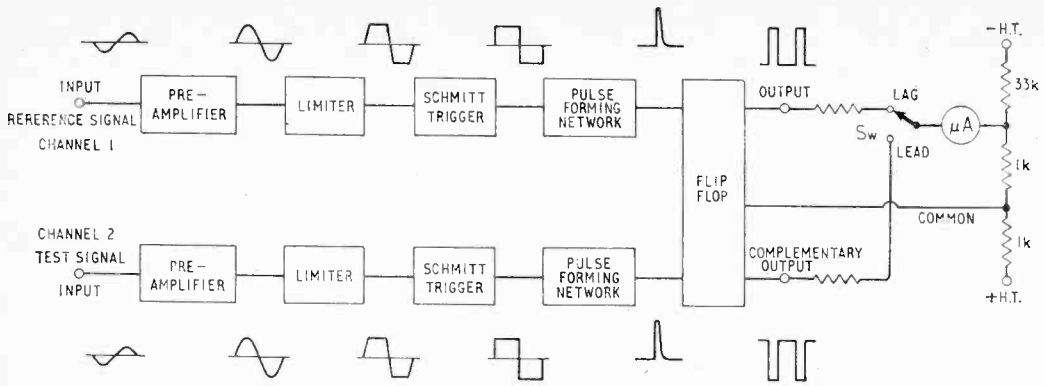

Fig. 1. Block diagram of transistor phasemeter.

most of the working range using a simple and straightforward circuit arrangement, provided that the reference and test signals are of approximately equal amplitude and come from sources of comparable internal output impedance. If higher accuracy is required it can be secured by the use of special calibration procedures similar to those used when making other precision a.c. measurements. Null methods or substitution measurements are two such possibilities.

The wave-shaping processes are most concisely described by reference to a block diagram. Fig. 1 shows schematically the whole range of operations which are carried out on the input reference signal and on the test signal of which the phase is to be determined. It will be seen that, up to the input terminals of the switching flip-flop, there are two identical signal channels with closely matched characteristics. The various functional blocks will be described briefly and then actual circuits will be discussed in more detail. It can be said at once that the only stage which presents any design problems is the limiter. Apart from the use of reasonably well matched components and transistors in the twin channels, the remainder of the circuit is quite conventional.

We start in each channel with a wideband pre-amplifier of moderate voltage gain and very high input impedance, such that negligible loading is imposed on the two signal sources. The high input impedance is achieved by a bootstrap arrangement.

The limiter stage comes next. It should have high gain and is required to produce a good square wave output from a low-level sinusoidal input. It is surprising how much amplification is required to produce from a low frequency sine wave a pulse or step voltage with a rise-time of the order of microseconds. Consider the sine wave $e = E \sin \omega t$. The rate of change $de/dt = \omega E \cos \omega t$ is clearly a maximum when $t = 0$. With $E = IV$ and $f = 50$ c/s, $\omega = 2\pi f = 314$ radians per second. Then at $t = 0$, $de/dt = 314$ volts per second. It is reasonable to require a pulse rise-time rate of 1 volt per microsecond, corresponding to $de/dt = 10^6$ volts per second. The gain required from the squaring amplifier is thus $10^6/314 = 3180$, calling for two, if not three, tandem stages. Alternatively, the input signal may be directly increased in amplitude but this is often inconvenient if not impossible. In Woodbury's design there is only one transistor pre-amplifier in each channel and this calls for an input of 4 V r.m.s.

at low impedance. The lowest operating frequency is 200 c/s but the limit can be lowered by increasing the size of the coupling capacitor to the flip-flop stage, although this tends to spoil the performance at very high frequencies.

Flip-flops using p-n-p transistors commonly require a triggering signal with an amplitude of several volts. It may be a positive pulse or a positive step voltage with a steep leading edge. Since it is difficult to produce this sort of trigger signal by means of a limiter, it is preferable to make use of regenerative switching circuits to follow a limiter of conventional design. A Schmitt trigger circuit is one possibility. Here two transistors are d.c. coupled by means of a common emitter resistance. If the input transistor is biased "off," the second is hard on and saturated. Conversely, if the first transistor is forward biased "on," the second is cut off. A small change of bias is sufficient to cause switching from one state to the other and there is no position of stability between cut-off and saturation. This Schmitt trigger stage constitutes the third block in each channel of the schematic shown in Fig. 1. The stage immediately preceding the output flip-flop is a pulse-forming network which turns the square wave output from the Schmitt trigger into a train of short-duration positive pulses. Each pulse in Channel 1 switches the flip-flop from one state to the other. Each succeeding pulse in Channel 2 switches it back again, the time delay between transitions being proportional to the phase difference

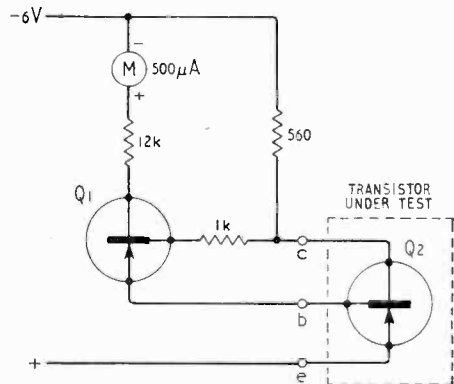

Fig. 2. Transistor test set due to J. J. Klinikowski.

between the input sinusoids to Channel 1 and Channel 2 respectively.

The flip-flop itself is a standard Mullard COMBI-element, type B 8 920 00, housed in a plastic case measuring $2\frac{1}{4}$ in \times 1 in \times 13/32 in. It has 10 short wire leads for the input, output and power supply connections. Circuit details are given later. When used for phase measurement, each of the two flip-flop outputs is a rectangular wave of the same frequency as the input signals to the phasemeter. One output is the complement of the other, since when one transistor is conducting the other is cut off. Phase indications are made on a high-resistance d.c. voltmeter which can be connected, through a change-over switch, to either of the output terminals. This voltmeter can be made direct-reading in phase angle. The change-over switch serves to distinguish between leading and lagging phase angles.

With this amount of background we can proceed with a detailed discussion of each circuit in the block diagram of Fig. 1. These are not complicated but the construction and testing of the phasemeter requires access to a wide-range audio oscillator, a multi-range meter, an oscilloscope and a resistance bridge or ohmmeter. Reasonably well matched transistors and components are required in corresponding positions in the two signal channels to give equal gain and phase shift or time delay. As regards the selection of transistors it is sufficient to match the d.c. current gains. This can be simply accomplished by the test rig shown in Fig. 2, due to J. J. Klinikowski³. In this, Q1 is a low-power transistor, preferably a high gain type, while Q2 is the transistor under test. With the supply voltage and component values shown, Q2 is caused to draw a saturation current, held constant at 10 mA. The microammeter measures the base current of Q2 required to draw this amount of collector current. The current gain is 10 mA divided by the measured base current. If this is 100 μ A or 0.1 mA, the d.c. beta is 10/0.1=100. No circuit adjustments are necessary and it is obviously possible to calibrate the meter so that it is direct reading in current gain. It is hardly worth taking the trouble to do this when the arithmetic is so simple; 500 μ A corresponds to $\beta=20$, 400 μ A to 25, 250 μ A to 40 and so on.

The Mullard COMBI-element requires two power supplies, nominally ± 6 V. The supplies actually used are ± 6.25 V, stabilized by Zener diodes. The earlier stages are operated from these supplies con-

nected in series, i.e. at 12.5 V, to give a greater signal handling capability and to provide trigger pulses of the requisite amplitude to the toggle circuit.

Pre-amplifiers:—Two of these are required, details of the circuit being shown in Fig. 3. The bootstrap connection gives an input impedance in excess of $\frac{1}{4}$ megohm. The transistor working point is stabilized by d.c. feedback. Except for the component marked with an asterisk, matched resistors should be used in corresponding positions in each amplifier. The starred component, shown as 39k Ω , should be selected by trial so that when a test signal is applied and gradually increased in amplitude, the onset of overload results in symmetrical clipping of the positive and negative crests of the output waveform. The voltage gain of each amplifier should be almost the same, although differences of up to 3 dB are tolerable.

Limiters:—Waveform clipping can be accomplished in several ways. One possibility is to use a pair of diodes (or low-voltage Zener diodes), connected back-to-back or in parallel-opposition, and fed from a high impedance source. This gives symmetrical clipping but provides no voltage gain. Alterna-

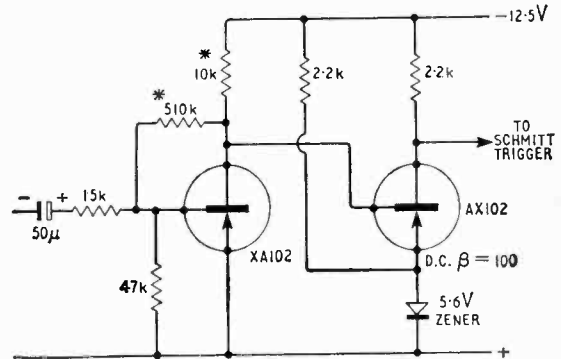

Fig. 4. Limiter circuit.

tively, an overdriven amplifier may be used as a limiter. It might be thought that nothing could be simpler than to amplify and clip a sine wave to produce a good square-wave output. The difficulty is that the clipping must be exactly symmetrical and this calls for an independent control of both positive and negative clipping levels and for the preservation of constant bias with variable input signals. Asymmetrical limiting causes departures from the desired mark-to-space ratio of unity in the output waveform, resulting in time-displacement of the zero-crossing points and consequent errors in phase angle measurements. Cathode-coupled clippers give a good performance with thermionic valves, but the transistor equivalent has insufficient gain for the present application. Practical tests show that the arrangement of Fig. 4 is superior. Two resistors, marked with an asterisk, need to be adjusted or selected to give the best waveform over a wide range of input signal levels. The best choice is determined by observing the limiter output waveform on an oscilloscope. By using a low-power 5.6 V Zener diode in the position shown, the two transistors may be d.c. coupled.

Corresponding components in the two limiter cir-

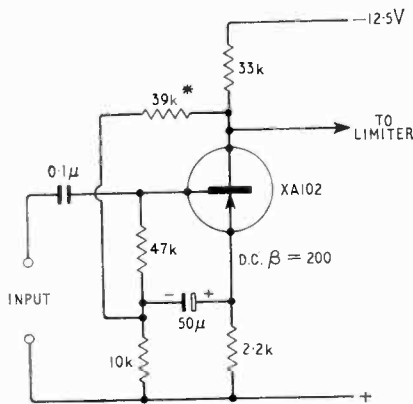

Fig. 3. Pre-amplifier circuit.

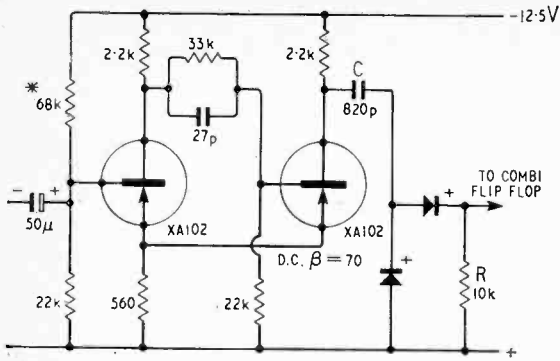

Fig. 5. Schmitt trigger and pulse-forming circuit.

circuits should be matched to within ± 5 per cent. The transistors should also be matched in pairs and should preferably have current gains in the range 50-150.

Schmitt Triggers and Pulse-forming Networks:—

Two of these are required, wired up as shown in Fig. 5. As before, matched components are required in the two channels, except for a single resistance in the input bias circuit. If this is significantly less than the value shown, the first transistor will be turned on while the second is cut off. If greater, the situation is reversed. The correct resistance value is the average of these two extremes. A slight variation of resistance one way or the other should cause a sudden switchover of production from one transistor to the other.

The pulse-forming network using two diodes and a short CR differentiating circuit produces a train of short-duration positive pulses from the square-wave output of the Schmitt trigger. The output pulses are used to switch the flip-flop stage now to be considered.

Flip-Flop Stage:—Fig. 6 is the complete circuit diagram of the Mullard COMBI-element flip-flop, type

B 8 920 00. It is obtainable in packaged form, ready for use. Physical details and pin connections are shown in Fig. 7. The unit requires two 6 V power supplies, one negative and one positive, connected to a common point, normally at earth potential. A current of about 6 mA is drawn from the negative supply and about 150 μ A from the positive source. It is convenient to use a centre-tapped power supply unit of say 6.25 V-0-6.25 V. The positive side may be loaded by a 1000-ohm resistor which will draw the same current as that taken by the flip-flop from the negative terminal. Both sides of the power supply will then be loaded equally.

Several other manufacturers, including Ferranti and Texas Instruments, also produce similar units. They are intended primarily for use as binary counters in digital computers and similar equipment. Most of them work reliably at switching speeds in excess of 100 kc/s, which is ample for phase measurements at 20 kc/s or more.

As previously stated there are two outputs from a flip-flop, one of which is the complement of the other. When used as a binary counter, each output is a square wave but one is of opposite polarity to the other. As used in the phasemeter, the outputs are rectangular waves with a mark-to-space ratio which depends on the time delay between consecutive trigger pulses and hence on the phase difference between the original input sinusoids.

The mean d.c. output voltage from each flip-flop terminal is measured by a 50-microamp meter in series with a high resistance. The voltmeter can be switched from one output to the other. Ideally, each flip-flop output should be zero when the associated transistor is turned on and saturated. In practice it will be around 0.2 V (negative) and so the meter will show a finite reading. It is backed off to zero by a potential divider consisting of two resistances connected across the 6.25 V negative supply. When either output transistor is cut off, its collector voltage should rise to -6.25 V but inspection of the flip-flop circuit will show that the true figure will be less than this and, unless both halves of the flip-flop are identical, the two outputs will be different. For this reason two separate

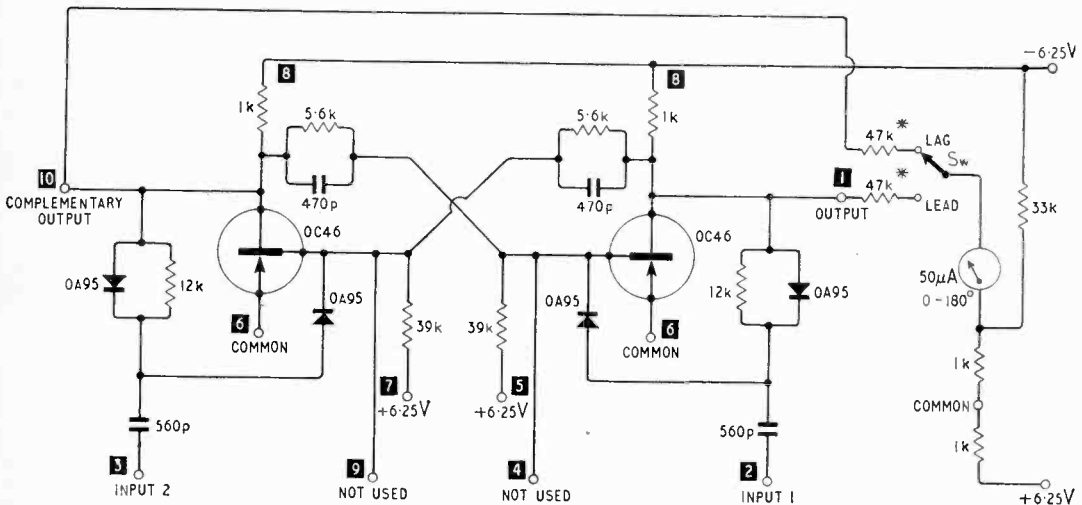

Fig. 6. Mullard COMBI-element flip-flop and phase indicating voltmeter.

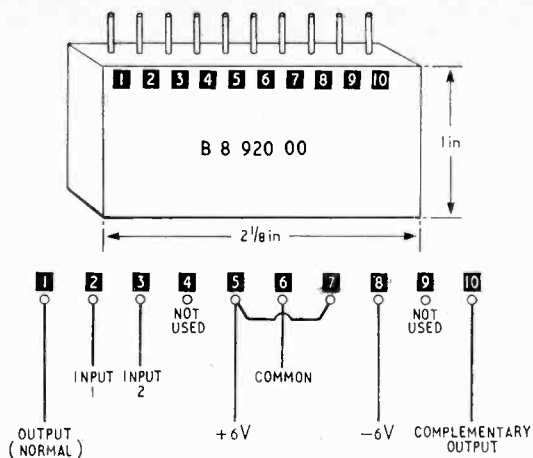

Fig. 7. COMBI flip-flop and pin connections.

voltage-dropping resistances are used in series with the basic meter movement in order to compensate for these inevitable differences. The meter should read exactly full scale, in either output position, when the flip-flop is delivering an exact square wave output, which corresponds to a phase difference of 180 degrees between the input reference signal applied to one channel and the test signal applied to the other. Such a test signal is easily generated by means of a small transformer having a centre-tapped secondary for producing the anti-phased voltages.

The complete phasemeter circuit is shown in Fig. 8. Component values are as already given in the diagrams of the individual units. The one marked resistor ($1k\Omega$), serves as already mentioned to equalize the loading of the positive and negative power supplies. The measured current drawn from the common point is less than 1 mA.

Power Supply Unit:—This is detailed in Fig. 9. It makes use of a small bell transformer (Friedland),

250 V to 8 V, rated at 3 VA. The secondary feeds a voltage-doubling rectifier, the d.c. output of which is filtered and regulated by two Zener diodes, 6.25 V 2.25 W. The total current drawn by the phasemeter is about 30 mA.

To avoid any possibility of hum pick-up by the high gain stages of the phasemeter it is best to house the power unit in a separate metal case. Alternatively, it can be fitted into its own screened compartment. Another advantage of a separate unit is that it may be replaced by batteries for use in special circumstances.

Construction:—Although the circuits are fairly complex, construction presents no particular difficulties. Some care with layout is required to give the greatest possible physical separation between the pre-amplifier input terminals and higher-power square wave and pulse circuits. Special screening is unnecessary.

A compact assembly is made possible if the wire ends of components are bent over and pushed through drilled holes in an insulating panel, point-to-point wiring being made on the back of the panel as in the case of printed circuits. Using this technique it is easily possible to fit the entire circuit into a metal case about 9 in. \times 4 in. \times 3 1/2 in.

Some potential constructors may be put off by the cost of transistors and components and by the reluctance of some manufacturers to deal with individual small consumers. In fact, all parts are available cheaply on the surplus market and the instrument can be built at a total cost of about five pounds. The microammeter is similar to that used in the *Wireless World* audio signal generator. The transistors are all Ediswan-Mazda Type XA 102. This is an extremely good general-purpose high-frequency transistor available from various sources at 2s. each. Resistors and capacitors are readily available as are 2 1/4 W Zener diodes for the power supply unit and 250 mW Zeners for use in the limiter stages. Rectifier and signal diodes are easily obtainable at low cost.

It is a good plan to build, adjust and test the

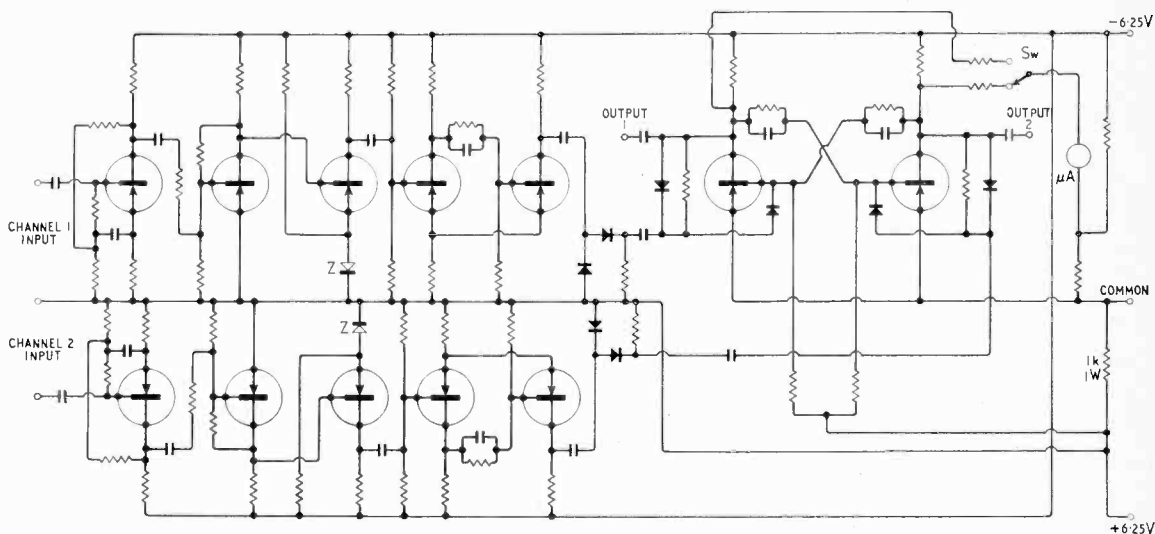

Fig. 8. Complete circuit diagram of phasemeter.

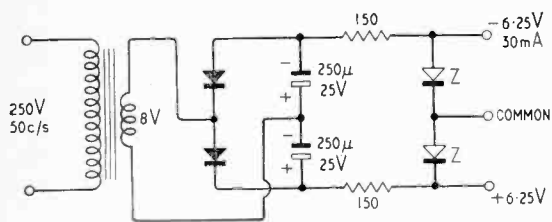

Fig. 9. Phasemeter power supply unit.

various sub-units as they appear on the block schematic diagram in Fig. 1.

Testing, Calibration and Operation:—As each sub-unit is constructed it should be tested and, where necessary, brought up to specification by adjustment or selection of the few components to which special reference has been made. Starting with the input pre-amplifiers, these should give a good output waveform over the range 20 c/s to 20 kc/s. They will normally overload with an input of about 200 mV and, beyond this point, clipping should be reasonably symmetrical. In practice, the phase-meter readings will be found to change only slightly when the pre-amplifier is quite heavily overloaded.

Next, the starred resistances of the clipper stages should be selected or adjusted by trial until a good square wave output is observed on the oscilloscope over a wide range of variation (say 10-20 dB) of input signal level. To make this adjustment it is perhaps easiest to use preset or variable resistors, set to give the best possible performance, and then to replace them by fixed resistors of the nearest preferred values.

Only one adjustment of the Schmitt trigger circuits should be necessary. This is to set the value of the base bias resistor of the first transistor to give the most sensitive triggering characteristic. The pulse-forming network following the Schmitt stage needs no adjustment.

If the flip-flop is bought as a unit no adjustment is necessary, or indeed possible. Constructed from reasonably well matched components it should need no subsequent modification. The switching signal from the pulse-forming network is large enough to give reliable triggering over a frequency range much wider than that specified. Calibration of the phase-indicating voltmeter is the last operation to be undertaken. It should read zero when both channel inputs are in phase and should read full-scale when they are in phase opposition. The first condition is satisfied by adjusting the backing-off bias established by the potential divider connected across the negative power supply. However, there is a difficulty which arises at this point. It will be recalled that the phasemeter works by deriving pulses from each input signal and then using one of them to change the flip-flop state. The next pulse in the other channel switches it back again. If the original signals are very nearly in phase, the two switching pulses will be almost simultaneous. Before the flip-flop has changed state in response to one pulse, the second pulse will attempt to switch it back again. If the pulses are absolutely simultaneous the flip-flop will behave like a binary counter and give a full-scale meter reading exactly as it would if the two inputs were in opposite phase.

This ambiguity disappears as soon as the inputs differ in phase by one or two degrees at low frequencies or by some slightly larger angle at 20 kc/s. To avoid the difficulty when calibrating the zero end of the phase indicator range, a phase lag of one or two degrees may be inserted into the test channel while supplying the reference channel direct from the signal source.

The 180-degree check point, corresponding to anti-phased input signals, is represented by a full-scale meter reading. Push-pull signals are most simply derived from a transformer with a centre-tapped secondary winding. With such an input, the two resistances in series with the meter movement should be adjusted in turn to give full-scale deflection with the change-over switch in either position.

It remains to mark the two pairs of input terminals. The reference signal should always be connected to one pair and the test signal (the phase of which is to be measured) to the other. The correct setting of the output switch has still to be determined. One position corresponds to a lagging and the other to a leading phase. To identify these, the best method is to insert a deliberate phase lag into the test channel by means of series resistance and shunt capacitance. The amount of phase lag introduced in this way depends on the signal frequency, the series resistance and the shunt reactance. In any event it cannot possibly exceed 90 degrees. With the output switch in one position, the meter will read less than half-scale. This position of the switch should be marked "LAG." In the other position the meter reading will be hard over, beyond full scale. No possible damage can be done since the available power in the meter is so small. This position of the switch should be marked "LEAD." It is the position to be used when the test signal is leading in phase with respect to the reference. Naturally, an interchange of the reference and test signal inputs has the same effect on the output meter readings as a change-over in the switch settings.

The meter actually used has three movable scales, selected by a lever at the back of the instrument. One of these is already calibrated 0-30 and is convenient for reading phase angles 0-180

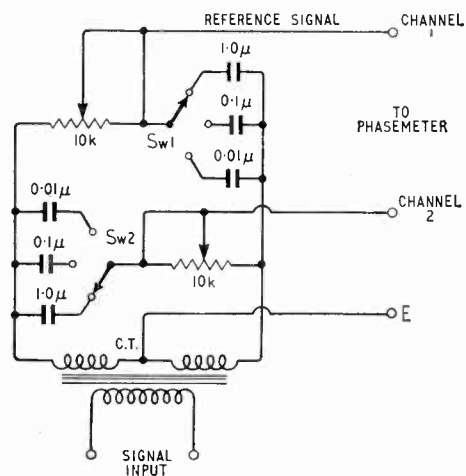

Fig. 10. 360-degree phase shifter.

degrees. The lever is locked permanently to keep this scale in use.

By making up the simple test equipment shown in Fig. 10 it is possible to test the phasemeter over a phase range of almost 360 degrees and at any frequency in the range 20 c/s to 20 kc/s. The two variable resistances are ganged together but connected in such a way that as one increases in resistance the other decreases. The transformer is a small unit with a centre-tapped secondary. The three pairs of switched capacitors cover the whole audio-frequency range.

The collectors of the output flip-flop may be brought out through capacitors to a pair of insulated terminals. The waveform at each collector may then be examined on an oscilloscope. Direct measurements of the mark-space ratio can then be used to give a useful check on the accuracy of the meter indications. The agreement is quite close. The indicator used has a well damped movement. If some other type is substituted it is possible that pointer flicker will be noticeable at low test frequencies. A complete cure can be effected

by tapping each voltage-dropping resistance and connecting a capacitor from the junction to the common point of the power supply. This RC filtering is sufficient to smooth out the pulsating meter current.

The instrument described is simple and compact, easy to use and is free from ambiguities of phase indication except when phase differences approaching zero are to be determined. It covers an exceptionally wide frequency range with an accuracy sufficient for most purposes, provided only that the input and reference signals are comparable in amplitude and come from sources of low or moderate output impedance.

REFERENCES

1. J. R. Woodbury, "Measuring Phase with Transistor Flip-Flops," *Electronics*, September 22nd, 1961, p. 56.
2. T. E. Reamer, "Phase Meter for Audio Frequencies," *Electronics World*, November, 1963, p. 43.
3. J. J. Klinikowski, "Simple Meter Circuit Indicates Transistor Beta," *Electronic Design*, August 16th, 1963, p. 96.

COMMERCIAL LITERATURE

"**Photodiodes and Phototransistors**" are described in an 8-page Mullard publication, obtainable from Mullard Ltd., Mullard House, Torrington Place, London, W.C.1. Circuits are given, which illustrate typical applications of these devices. A section on the photoelectric effect and basic illumination theory is also included.

12WW 326 for further details

Leaflets describing "low frequency recorders," with interchangeable pre-amplifying channels, and "pre-amplifying interchangeable channels," for low-frequency direct-writing recorders, manufactured by Officine Galileo, of Florence, Italy, are available from Leland Instruments Ltd., 145 Grosvenor Road, Westminster, London, S.W.1.

12WW 327 for further details

Transradio Connectors.—Transradio Ltd. have just published a new 148-page connector catalogue, the first since 1960. It contains detailed information, illustrations and outline drawings, of well over 400 screened connectors. Cross-reference lists of U.S. Military numbers, British N.A.T.O. stock numbers, Air Ministry reference numbers, Admiralty Pattern numbers and Transradio code numbers are also included. Copies of this catalogue are available from Transradio Ltd., 138A Cromwell Road, London, S.W.7.

12WW 328 for further details

An "Abridged Catalogue of Semiconductors," dated June 1964, has been forwarded to us from the Electronic Apparatus Division, Valve and Semiconductor Group, Associated Electrical Industries Ltd., Carholme Road, Lincoln. A wide selection of silicon and germanium devices, and an A.E.I. equivalents list, are included in this 30-page catalogue.

12WW 329 for further details

A number of leaflets, in English, have been sent to us by C.S.F. (**Compagnie Générale de Télégraphie Sans Fil**), 79 Boulevard Haussmann, Paris 8. Leaflet No. 1223 describes their 7 Gc/s f.m. mobile television repeater, No. 1422/2 a transistor 3-30 Mc/s radiotelegraph receiver rack, No. 1403/1 an optically pumped caesium vapour magnetometer, and No. 1415/A describes their SM100A mass spectrometer.

12WW 330 for further details

Standard voltage, current and power transformers are described in a leaflet obtainable from Smith Hobson Ltd., Hershman Trading Estate, Walton-on-Thames, Surrey. A brief résumé of the products, which range from low voltage metering and laboratory testing transformers to 15,000 A current supply transformers, is given in French, German, Italian and Spanish.

12WW 331 for further details

"**Ultra-pure elements, single crystals and inorganic compounds**" is the title of catalogue M-5, which is now available from the Pure Elements Division of Koch-Light Laboratories Ltd., Poyle, Colnbrook, Bucks. Some 775 forms and compounds of 82 elements are listed in this 32-page publication.

12WW 332 for further details

Leaflets giving tentative specifications on the MD100 low-capacitance silicon planar epitaxial varactor diode and the MS100 solid-state microwave signal source (5.4 to 5.9 Gc/s) are obtainable from SGS-Fairchild Ltd., Stonefield Way, South Ruislip, Middx.

12WW 333 for further details

Power supply units manufactured by The Belix Company are described in a loose-leaf catalogue recently forwarded to us from their head office, 47 Victoria Road, Surbiton, Surrey. It is split into two sections, the first covering sub-units for use in equipments which require a single voltage (or two single voltages) in the range 0 to 30 V and have a current consumption of under 15 amps. The latter covers laboratory bench models with outputs of up to 10 A in the voltage range 0 to 50, and up to 15 A in the voltage range 0 to 30 V.

12WW 334 for further details

Lumped constant delay lines for computer, communication and telemetry applications are described in Hi-G Inc. catalogue No. EM-1. Copies are obtainable from Spring Street & Route 75, Windsor Locks, Connecticut, U.S.A., or from their Italian plant Hi-G d'Italia S.p.A., 276 Corso della Repubblica, Cisterna di Latina, Italy.

12WW 335 for further details

LETTERS TO THE EDITOR

The Editor does not necessarily endorse opinions expressed by his correspondents

Light Beam Modulation

I WAS most interested in the contribution from A. J. Goss and A. E. Sarson in the August issue. The description of the early experiments at M.I.T. was brought to the notice of some of my colleagues and myself during the autumn of 1962. Light-emitting diodes were not then commercially available and it was decided to try an alternative approach to the transmission of wide-band signals over a light beam.

The transmitter utilized a Ferranti CL62 vacuum light source. This can best be described as a cathode-ray tube with no deflection or focusing electrodes. The tube face is coated with a phosphor having a spectral response peaking at 0.4 microns and a decay time of approximately 0.1 microseconds. The spot of light formed on the tube face was approximately 2 inches in diameter and light from this was collected by a lens 6 inches in diameter with a focal length of 9 inches.

The light was collected at the receiving end by a lens similar to the one used in the transmitter and focused on to an R.C.A. 931A photomultiplier.

The signal was provided by a 625-line, random-interlace television camera which was used to feed a voltage amplifier with an output voltage swing sufficient to drive the grid of the tube. At the receiving end the output from the photomultiplier was passed through an amplifier consisting of an ECF80 with the pentode section used as a voltage amplifier and the triode section used as a cathode follower. The cathode follower output was used to drive a monitor.

The equipment worked satisfactorily over a distance of 50 feet indoors. The maximum range would almost certainly have been much longer but we ran out of corridor before we ran out of signal. The project was shelved before it was tried out of doors. At 50 feet range the signal-to-noise ratio was such that there was no noticeable difference between the transmitted and received pictures. The frequency response was also excellent. The phosphor used on the transmitting tube appeared to have a very non-linear characteristic giving rise to gamma distortion and cramping of the sync. pulses. This latter effect made the setting of the controls in the monitor rather critical. This could be overcome by the addition of gamma correction circuits.

The project was abandoned because atmospheric absorption and scattering would be troublesome in any long-distance link using ultra-violet. There appears to be no phosphor with an infra-red output and a fast response. The optics were much more crude than those of Messrs. Goss and Sarson, and the extra range must have come from the increased light output. There is no doubt that the future is very rosy for the gallium arsenide lamp but means did exist before its discovery for transmitting wide-band signals over a non-coherent light beam.

Nottingham

H. R. BEASTALL

Transistor F.M. Tuner

I WAS delighted to see, in the July issue, the article on the construction of a pulse-discriminator f.m. tuner, because I feel that this type of tuner deserves much wider use than it has had so far.

I built a tuner of this type in 1958, and it has been in regular use in my home ever since, having a performance, as far as I can judge, which leaves nothing to be desired. I gave a lecture on the design of this receiver to the South Midlands Section of the I.E.R.E. (then Brit.

I.R.E.), with a practical demonstration, but, regrettably, I never got around to writing it up!

The tuner employs three valves and four semiconductor diodes, but my colleague R. C. Bowes built an experimental all-transistor receiver even earlier on, and this used a monostable trigger circuit as the discriminator in a very similar manner to the recent *Wireless World* design. At the time, I took the decision that a valve design would be easier and cheaper to make as an answer to my immediate domestic need for a good f.m. tuner. Whilst my design owes much to the interesting articles by M. G. Scroggie^{1,2}, it does also have some novel features which I thought might be of interest to a few readers.

The discriminator is of the "diode pump" type as used by Scroggie, but the limiting is performed in the anode circuit of the final i.f. pentode by a pair of diodes (OA5) arranged to limit the a.c. anode voltage excursion to 12 volts peak-to-peak. This arrangement is much more economical in i.f. amplifier gain than that used in the Scroggie design, satisfactory limiting being obtained for an input voltage to this final i.f. stage of 200 millivolts r.m.s., as compared with several volts at the grid of the pentode limiter used by Scroggie.

The rest of the tuner employs a double triode, which functions as a self-oscillating frequency changer plus first i.f. stage, and there is a pentode r.f. stage. A very good performance is obtained provided the aerial input voltage is at least a few hundred microvolts—I get about one millivolt from a loft dipole here. However, for more general use, another i.f. stage would have been desirable, but I am afraid my interest turned to other matters before the task of building a second receiver, elegantly laid out and written up as an article suitable for home constructors, was accomplished!

Another feature of this tuner is that, although switch selection of the three B.B.C. programmes is employed, there is neither crystal control nor a.f.c., yet no trouble has been experienced with local oscillator frequency drift. First-class quality is obtained from the moment the local oscillator starts oscillating, and very little re-adjustment has been required on the approximately annual occasions when the tuning has been checked. I did give rather careful attention, however, to the design of the local oscillator (which works at about 45 Mc/s), and my conclusion was that, provided one adopted a sensible circuit design, the real problem was simply that of making the L-C tuned circuit itself have a sufficiently low temperature coefficient of frequency variation. This was solved by the use of ceramic capacitors of the right temperature coefficients.

The six-turn oscillator tuning coil is $\frac{3}{8}$ in dia., 14 s.w.g. wire, giving a Q of around 200. The valve electrodes are well tapped down on the tuned circuit, so that the effective C/L ratio as seen by the valve is very large compared with more usual local oscillator designs; the tuned circuit capacitance, referred to the valve anode/cathode circuit, is, in fact, about 400 pF. The principles used are, of course, well known^{3,4}, but do not seem to have been widely used in f.m. receivers.

With this oscillator circuit, one can even replace the valve without returning being absolutely necessary—five valve samples tried gave i.f.s. varying ± 35 kc/s about the nominal 160 kc/s. The warm-up frequency drift is about 20 kc/s at i.f., i.e., the oscillator frequency changes by about 1 part in 4,500. This has no detectable effect whatever on quality, the discriminator characteristic being very linear up to an i.f. frequency of about 350 kc/s.

Satisfactory frequency stability is even more readily obtained using transistors, since there is virtually no

warming up—the problem is simply to reduce the effects of ambient temperature variations to a sufficiently low level. This, again, presupposes a good circuit design, but we have found that this presents no great difficulties. I am convinced, indeed, that a sufficiently stable transistor LC local oscillator can be made quite cheaply and that it would not need individual adjustment to achieve the required stability.

I have given some thought, over the past few years, to the design of a transistor tuner of this type, and I have tended to come to the conclusion that whereas the monostable trigger circuit type of discriminator is clean and straightforward, it needs short pulses to drive it if low distortion is to be obtained, and this leads to the use of more transistors and associated components than are necessary if a simple square-wave limiter and diode pump discriminator are used.

Thus, whilst I had contemplated making a transistor f.m. tuner costing, perhaps, only about half as much as the *Wireless World* model, I would like to congratulate you on having produced a good design, which should prove very straightforward to build and which requires virtually no adjustment at all—a great advantage for many readers, which may well justify the extravagance of the three quartz crystals.

The only thing I regret about the article is that the circuit diagram is, in the opinion of my colleagues and myself, drawn upside down!

Great Malvern

PETER J. BAXANDALL

1. "Low-Distortion F.M. Discriminator," by M. G. Scroggie, *Wireless World*, April 1956.
2. "Unconventional F.M. Receiver," by M. G. Scroggie, *Wireless World*, June 1956.
3. "High-Stability Oscillator," by G. G. Gouriet, *Wireless Engineer*, April 1950.
4. "An Inductance-Capacitance Oscillator of Unusual Frequency Stability," by J. K. Clapp, *Proc. I.R.E.*, March 1948.
5. "Collectors Upwards or Positive Upwards," by P. J. Baxandall, *Wireless World*, Jan. 1962.

Intermodulation Distortion Measurement

I AM grateful to Mr. Waddington (August issue, page 399) for the opportunity of replying to the four points he considered valid for rejecting the slotted noise distortion measurement method without a mention.

1. I agree that the method forms a suitable test for production items in view of its relative quickness. This does not stop it being even more useful in the development stage to decide whether the item is worth producing in the first place! Where does he get his "only" from? Is my idea "only" just right?

2. The test will decide precisely between second- and third-order distortion. The rate of change of noise power ratio is two dB/dB input for second and three dB/dB input for third.

3. As third-order distortion is roughly uniformly spread over the band, this method does not provide a ready means of deciding whether the equipment distorts more at high or at low frequencies. In view of its even distribution does Mr. Waddington consider this really important? He could always use the three filter frequencies suggested in our article.

4. We are now at the real root of the trouble. Harmonic methods date from the time when amplifiers were small and were always overloaded. This was twenty-eight years ago. In those days the overload point was important. No engineer today would dream of installing amplifying equipment which would overload precisely at the specified output. The B.B.C., for instance, expect at least 6 dB margin on programme channels, at least in the early stages. It follows that it is an anachronism to argue that the distortion at overload point has any significance.

The virtue of white noise as an amplifier test signal lies precisely in its nature: it resembles programme better than any other controllable signal. In particular, the ratio between mean power and peak power must be observed or intolerable distortion will result. We chose 9 dB for time in overload of 0.01 % and added one for

other tolerances. The I.T.T. and ourselves must be using the same mathematics!

We now have the final piece of non-logic. How can a system which gives the actual distortion noise power be accused of optimism or pessimism? Surely it is the old harmonic type measurements, which we both agree to be uninterpretable because ambiguous, which were, before Richards and I showed the light, accepted as normal, that must now be regarded as pessimist or optimist?

Many surprising observations will be made when the slotted white noise method becomes recognized. But, as everyone concerned in the correspondence knows, the old methods are clung to out of habit—and—perhaps availability. Shall I really have to become a manufacturer myself before I can get rational ideas accepted?

London, N.W.2

J. SOMERSET MURRAY

Optical Analogue

THOSE of your readers who are familiar with modern optical theory will have recognized, in Mr. Smethurst's suggestion (August issue, page 402), the underlying idea of optical frequency response techniques. Probably the first book to deal with this work was Professor Duffieux's "L'intégrale de Fourier et ses applications à l'optique," written during the war and published in 1946 (privately printed). Since then, a considerable number of articles dealing with optical frequency response techniques have appeared; much of the English work was performed by Professor Hopkins and his colleagues at Imperial College, and by Dr. Linfoot and others in Cambridge, and a very useful survey of the topic is to be found in Dr. Linfoot's "Qualitätsbewertung optischer Bilder" (Vieweg, Braunschweig, 1960). The subject is well covered in Born and Wolf's "Principles of Optics" (Pergamon, 1959, new ed., 1964).

Cambridge

P. W. HAWKES

International Trade Show

DURING the first week of the National TV & Radio Show a separate exhibition of imported radio equipment is being held in London. Its full title is International Radio and Electrical Trades Exhibition and it is being held from 24th-29th August (10 a.m.-8 p.m.) at the Prince of Wales Hotel, de Vere Gardens, W.8. The show is being supported by the following importers:—

Acme Electric Co.	Lee Products
Argelane	Light & Sound
Ataka & Co.	Marubeni-Iida Co.
Benkon	Stokvis & Sons
Denham & Morley	TAK Continental Importers
Europa Electronics	Tellux
Green Arrow (Intercontinental)	United Africa Mechanical &
Hall Electric	Electrical Co.
Heddon-Smith & Co.	Welmecc Corporation
Kuba Sales & Service	Wholesale Supplies

The show is primarily for the trade but from 2.0 each day the public will be admitted free.

Other Trade Shows

Some manufacturers and distributors are holding individual shows in London. They include:—

- Bosch (Aug. 24-29) at 205 Gt. Portland St., W.1.
- Brown Brothers (Aug. 24-Sept. 4) at Bailey's Hotel, Gloucester Rd., S.W.7.
- Celestion (Aug. 28, 29, Sept. 4 & 5) at Rembrandt Hotel, Thurloe Place, S.W.7.
- Daltrade (Aug. 24-Sept. 3) at May Fair Hotel, Berkeley Sq., W.1.
- Elizabethan Tape Recorders (Aug. 24-29) at May Fair Hotel, Berkeley Sq., W.1.
- Grundig (Aug. 25-29) at London Hilton, Park Lane, W.1.
- Highgate Acoustics (Aug. 23-29) at Kensington Palace Hotel, de Vere Gdns., W.8.
- Lugton & Co. (Aug. 24-27) at Café Royal, Regent St., W.1.
- Saba (Aug. 25-27) at the Dorchester Hotel, Park Lane, W.1.
- St. Aldate Warehouse (Aug. 24-29) at Carlton Tower Hotel, Cadogan Place, S.W.1.
- John Street (Aug. 25-Sept. 3) at Café Royal, Regent St., W.1.

COURSES IN RADIO AND ELECTRONICS

DETAILS of a large number of courses to be held at colleges and evening institutes up and down the country during the coming academic year have been sent to us and from these we have selected the following as being of particular interest to *Wireless World* readers.

The Imperial College of Science and Technology, London, has issued a 174-page book giving details of **post-graduate courses and research** available in the various departments during the 1964-65 academic year. Separate pamphlets are also available for each of the departments. In the programme for the Electrical Engineering Department there are courses covering various aspects of communication and electronics, automatic control systems, applied electron physics and medical and biological electronics. One-year courses of advanced study in mathematical physics, applied optics, photo-electronics and physics are provided in the Physics Department.

A post-graduate course in **applied acoustics**, leading to the degree of M.Sc., has been introduced by the Manchester College of Science and Technology. Details of the three-term full-time course, for which the fee is £83 10s for students from the British Isles, are obtainable from The Manchester College of Science and Technology, Manchester 1.

Full-time courses leading to City and Guilds examinations in radio and television servicing, electronics servicing and telecommunications are being run at the Isleworth Polytechnic, St. John's Road, Isleworth, Middx.

Among the evening courses available at the **Portsmouth College of Technology** are the following:—"An outline of statistical communication theory"; "Control systems theory" and "Digital techniques".

The prospectus from the **Northern Polytechnic**, London, N.7, includes details of a large number of full-time and part-time specialist courses as well as those leading to the graduateship of the I.E.R.E. The college also runs full-time courses in radio, television and electronic servicing leading to the certificates of the City & Guilds and Radio Trades Examination Board.

Wandsworth Technical College, London, S.W.18, provides a series of evening courses for the O.N.C. and H.N.C. in electrical engineering. Among the special courses are three on transistors (afternoons or evenings), a one-year evening course on electronic measurements, a 12-week evening course on technical writing techniques and another on modern electrical test equipment.

Six evening lectures in **television techniques** in industry and broadcasting will be given on Tuesday evenings from 13th October at Norwood Technical College, Knight's Hill, London, S.E.27.

Transistors.—Three afternoon or evening courses on transistors are to be given at the Borough Polytechnic, London, S.E.1. The first (12 lectures) on transistors and allied devices begins on 29th September; the second (12 lectures) giving an introduction to the theory and applications of transistors also begins on the 29th and the third, a laboratory course in basic transistor measurements, on 14th October.

The 1964/5 prospectus of part-time courses in the Dept. of Electrical Engineering & Physics at the **Twickenham College of Technology** details courses for

O.N.C. and H.N.C. with endorsements, for I.E.E. and I.E.R.E. graduateship; and special short full-time and evening courses covering basic electronics, computer engineering, fundamentals of semiconductors and transistor circuit design.

Among the post-graduate courses provided at **Brunel College**, Acton, London, W.3, is a one-week, full-time course on digital engineering techniques beginning on 2nd November. Evening courses listed cover electrical instrumentation and measurements (10 lectures), varactor diodes (8 lectures), information theory (12 lectures) and theory and design of switching circuits (12 lectures).

Radio Amateur Exam. evening courses are to be held at:—

Birkenhead Technical College (Thurs.).
Birmingham: Lea Mason Centre, Central Evening Inst., Bell Barn Rd., 15 (Mon.).
Brentford Evening Inst., Clifden Rd., Brentford (Mon. and Thurs.).
Derby & District College of Technology, Kedleston Rd., Derby (Tues. and Fri.).
Glasgow: Allan Glen School, Montrose St. (Tues and Thurs.).
Leicester College of Technology (Wed.).
Wembley Evening Inst., Copland School, Wembley High Rd. (Mon.).

Books Reviewed

Practical Stereophony by H. Burrell Hadden. Written by a member of the B.B.C. staff, this book covers every aspect of stereophony from the historical background through theories of hearing to microphone techniques and recording, and the art of stereo reproduction in small and large auditoria. Pp. 159. Iliffe Books Ltd., Dorset House, Stamford Street, London, S.E.1. Price 37s 6d.

Flight Test Instrumentation: Volume 2, edited by M. A. Perry. Further record of papers read and discussed at the Second International Symposium held at Cranfield in 1962. A total of fourteen papers on instrument techniques and experience with complete systems are included. Pp. 256. Pergamon Press, Headington Hill Hall, Oxford. Price 80s.

Handbook of Electronic Charts and Nomographs, by Allan Lytel. Published originally in America, and now with an introduction for the English reader by W. Oliver, it contains 58 nomographs for rapid calculation. A useful feature is a translucent plastic sheet which can be folded over any chart and used for temporary pencil work. Pp. 58. Foulsham-Sams Books, Slough, Bucks. Price 35s.

Abstracts of Papers published in J.Brit.I.R.E. 1952 to 1963. Over 900 papers, articles and reports arranged according to the Universal Decimal Classification and supplemented by an alphabetical subject index and an authors index. Pp. 107. The Institution of Electronic and Radio Engineers, 9, Bedford Square, London, W.C.1. Price 10s 6d.

British Standard 204: 1960. Supplement No. 1 (1964). Glossary of terms used in telecommunication (including radio) and electronics, now extended to include terms used in wire broadcast and broadcast relay. Pp. 7. British Standards Institution, 2, Park Street, London, W.1. Price 3s.

Elements of Transistor Pulse Circuits

8.—BLOCKING OSCILLATORS

By T. D. TOWERS,* M.B.E.

IN modern electronics there is often a requirement for a large-amplitude, sharp-edged pulse of short duration (anything from a millisecond down to a fraction of a microsecond). One circuit widely used for this purpose is the blocking oscillator—particularly where the pulses have to be widely spaced in time. The blocking oscillator is basically a single-transistor, transformer-coupled-feedback oscillator with special properties. Anyone interested in electronics should know something of its design and uses.

Practical blocking oscillator circuits, stripped of refinements, reduce to one or other of the three basic feedback arrangements of Fig. 74. In Fig. 74(a) feedback is from collector to base with phase reversal through the transformer; in Fig. 74(b) from collector to emitter in phase; and in Fig. 74(c) from emitter to base in phase. Whatever configuration is used, the circuit produces an output pulse with the characteristic general shape shown in each case in Fig. 74, i.e., a rectangular pulse with a reverse overshoot on the trailing edge.

The blocking oscillator may be arranged as a monostable ("single-shot") circuit which remains

switched off until suitably triggered and then produces a single output pulse. Again it may be arranged as an astable ("free-running") circuit which produces by itself a string of pulses at a fixed repetition rate without the need for external triggering. The principal difference between astable and monostable versions is that the free-running version has a forward d.c. bias on the emitter and the monostable a reverse bias. Apart from this, design considerations for blocking oscillators are largely the same for both versions.

While single pulses can be provided only by a triggered monostable blocking oscillator, a pulse train can be provided in three ways: from (a) an astable blocking oscillator free running by itself, or (b) an astable blocking oscillator synchronized by an input pulse train at a frequency higher than the natural repetition rate of the astable, or (c) a monostable suitably triggered by an input pulse train.

The blocking oscillator circuit was apparently first developed by Appleton, Herd and Watson Watt (British Patent 23254) about 1923. When transistors arrived on the scene in 1948, it was soon found that the circuit took kindly to them. Whether with valves or transistors, however, the rigorous theoretical design of the blocking oscillator is extremely complex. On the other hand, the basic working principle is not all that difficult to understand, and it is possible to arrive at a simplified practical approximate design procedure. With this you can build a blocking oscillator to give something near the results you want, and then adjust to your exact requirements by intelligent cut-and-try at the end.

Fig. 74. Three basic feedback arrangements in blocking oscillator. (a) Collector-base, (b) collector-emitter, (c) emitter-base.

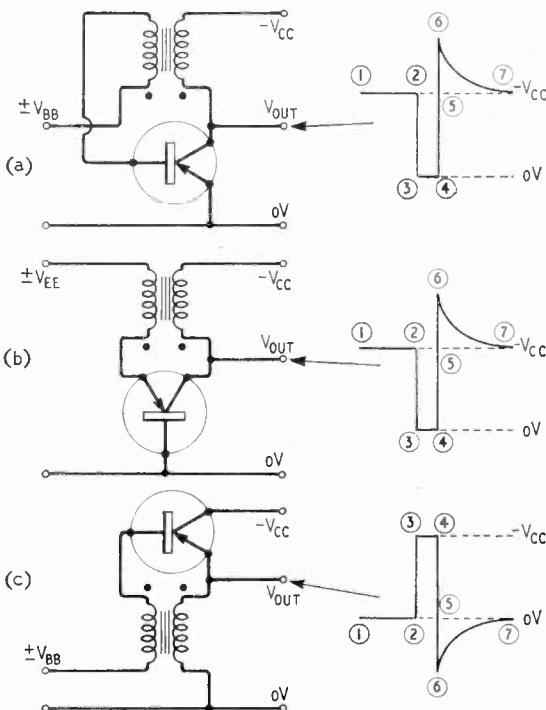

Operating Principle

Ignoring for the present the difference between astable and monostable versions, let us consider generally how a blocking oscillator works. Fig. 74(a) can be used for illustration. Assume for a start that the base bias voltage, V_{BB} , is zero. As the base-emitter diode is not forward biased, the transistor is cut off (no collector current flowing). In the absence of collector current, the collector is at the negative rail potential, point (1) on the output waveform illustration. If now a short negative pulse voltage, $-V_{BB}$, is applied to the transistor base (via the transformer winding), the base-emitter diode will go into forward conduction and collector current will begin to flow. This will cause the collector potential to start moving from the negative rail towards zero volts, from point (2) on the waveform. This positive-going change in collector voltage is phase inverted through the transformer and appears as a negative-going voltage at the transistor base. Phasing dots are inserted in Fig.

* Newmarket Transistors Ltd.

74(a) to make this easier to follow. The negative-going feedback voltage at the transistor base adds regeneratively to the negative trigger input voltage, and the transistor switches very rapidly into bottoming. This means that the collector voltage approaches close to zero volts at point (3) on the waveform.

The full rail voltage is now impressed across the transformer collector winding. The transistor remains bottomed during the pulse period, from point (3) to (4), and the current through the transformer builds up linearly until it is limited by some circuit parameter.

When the transformer current stops increasing at point (4), the feedback voltage to the base disappears, and the transistor begins to switch off. This causes the collector current to fall off, and the collector voltage to move back from zero volts towards the negative voltage rail again. This negative-going collector voltage is reflected by phase inversion through the transformer, as a positive-going voltage at the transistor base. This tends to turn the transistor farther off (provided, of course, that the input trigger pulse, $-V_{BB}$, has ceased). The circuit thus switches regeneratively back to the condition where the transistor is completely cut off, and the collector is once more at the negative rail voltage, point (5) on the waveform.

Because of transformer inductance, however, the collector voltage overshoots the rail voltage to reach point (6) before returning finally to the rail voltage, $-V_{CC}$, at point (7). This end point corresponds to the initial state at point (1), and the blocking oscillator is ready to be triggered again.

The exact shape of the overshoot depends on the various losses and reactance in the practical circuit, but, other things being equal, the height of the overshoot tends to be proportional to the pulse width. Whatever the exact pulse shape, all blocking oscillator output pulses have this "trade mark" of an essentially rectangular pulse with a reverse "pip" on the back end.

Timing Mechanisms

We mentioned above that the pulse terminates when circuit limitations prevent further increase in the magnetizing current in the transformer. In practice, circuit limiting methods used reduce to six as follows:—

- (1) "Beta-limitation", where the collector current limits in the end because the transistor current gain ("beta") has a finite upper limit.
- (2) "Core-saturation", where the transformer core is designed to saturate when the magnetizing current rises sufficiently to bring the core magnetic flux up to its limiting value.
- (3) "RC-limitation", where the standing d.c. bias on the circuit is set up by an RC network, and the "on" base current is finally limited by the discharge of the capacitor.
- (4) "Switch-off-limitation", where the pulse is precisely terminated by an external reverse trigger pulse applied to an input.
- (5) "Tuned-circuit-limitation", where a tuned circuit is inserted in the feedback loop. This oscillates when pulsed and gives an initial peak to start the blocking cycle and a second peak separated by a defined time to terminate it.
- (6) "Delay-line-limitation", where a pulse gener-

ated by the blocking oscillator switch-on is fed into a delay line, and the pulse coming out of the delay line after a fixed delay switches the circuit off.

Which of these timing mechanisms you use depends on several factors. Where very precise pulse width control is essential, it is advisable to use either switch-off, tuned-circuit, or delay-line limitation, because they give pulse widths virtually independent of supply voltage, circuit loading and transistor characteristics (except minority carrier storage). However, it can be quite expensive to ensure precise pulse widths by these methods. The other control methods may give less precise pulse widths but are more economical. Limiting by the transformer inductance (as in beta or core limiting) or by C (as in RC limiting) is simple and cheap. With beta or RC limiting, the pulse width is sensitive to circuit loading and transistor characteristics—particularly input impedance. With core saturation, the pulse width is less dependent on transistor characteristics and circuit loading; but in this case pulse widths are sensitive to supply voltage and consideration may have to be given to core-resetting.

Switching Cycle Detail

We showed idealized vertical edges to the output voltage pulse in Fig. 74 earlier. A real pulse would take a shape more like Fig. 75. Here the pulse is initiated at point (a), time t_0 . At point (b), time t_1 , it has risen to 10% of the full amplitude and ($t_1 - t_0$) is known as the "delay time." At point (c), time t_2 , the pulse has risen to 90% of the full amplitude, V_P , and ($t_2 - t_1$) is known as the "rise time." The pulse top, ideally flat, actually "drips" to point (d), time t_3 , as shown in Fig. 75, before the circuit begins to switch off. The pulse width can be taken as ($t_3 - t_2$). The pulse then falls to zero at point (e), time t_4 , and ($t_4 - t_3$) can be taken as the "fall time." The pulse overshoots to a reverse amplitude V_R , at point (f), time t_5 , before returning to zero at point (g), time t_6 . Here ($t_6 - t_4$) is the blocking oscillator "recovery time."

For pulse lengths greater than a few microseconds, the delay, rise and fall times are so short with modern transistors that they can be ignored in most designs, provided a suitable transistor is selected. Complex formulæ exist for computing these rapid transient switching times, but for "ordinary" requirements they are of somewhat academic interest. A practical rule of thumb is to select a transistor with f_{co} greater than $(10/T_P)$ Mc/s where T_P is the desired pulse length in microseconds. The pulse rise and fall times will then be sufficiently fast compared with

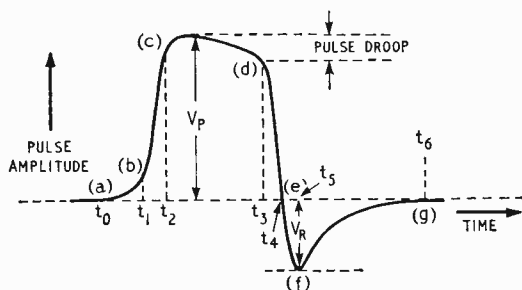

Fig. 75. Details of output pulse shape.

the pulse duration to be ignored. (For very short pulse widths of the order of a microsecond or less, it may not be possible to ignore the switching times and the designer will then have to consult one of the standard full treatments such as "Junction Transistor Blocking Oscillators," by J. G. Linvill and R. H. Mattson, *Proc. I.R.E.*, Vol. 43, No. 11, November 1955, pp. 1632-1639.) For the rest of this article we will assume negligible rise and fall times.

Pulse droop too is not a critical problem with most designs, and except for very long pulse lengths of the order of several hundred microseconds can be ignored in practice. We will not deal further with it in this article.

Design Requirements

Ignoring rise and fall times and pulse droop, we now turn to the main basic design requirements for a blocking oscillator. Anyone trying to design a blocking oscillator has to meet requirements of (a) pulse width, (b) pulse amplitude, (c) load resistance, (d) overshoot amplitude, and (e) recovery time.

The basic circuit of a blocking oscillator has three degrees of freedom:—

(a) *The timing mechanism* may be any of the several methods detailed earlier. It is not possible to give here a satisfactory treatment of all of these. It is proposed to limit the discussion to beta and core limiting circuits. Readers interested in RC, switch-off, tuned-circuit, or delay-line termination of the pulse should consult standard text-books such as K. W. Cattermole "Transistor Circuits" (Heywood, 1959) or S. Schwartz "Selected Semiconductor Circuits" (Wiley, 1960).

(b) *Saturated or non-saturated transistor operation* may be used. When we discussed the operating principle earlier, we assumed the transistor saturated or "bottomed" during the pulse, and this circuit is commonly referred to as a "saturated" blocking oscillator. For higher speed operation, it is sometimes desirable to prevent the transistor bottoming by clamping its collector through a diode to a fixed "hold-off" voltage source. We will consider the simpler saturated blocking oscillator first and cover non-saturated versions later.

(c) *The transformer feedback mode* must be chosen appropriately, from collector to base, collector to emitter or emitter to base.

Illustrative Design for Monostable Saturated Blocking Oscillator

As a first approach to the design, we will consider a monostable, saturated, collector-base feedback, blocking oscillator and give a "cookery-book" design equation for both beta and core limiting which are simple and accurate enough for most applications. Fig. 76(a) gives the basic circuit. The circuit as shown can be either beta or core limited. Both timing mechanisms use the same type of circuit (although component values will not be the same).

Theoretically the base and emitter resistors, R_B and R_E , are not essential to the operation. However, external resistances are normally included in practical oscillators to swamp the effect of the internal resistances of the transistor.

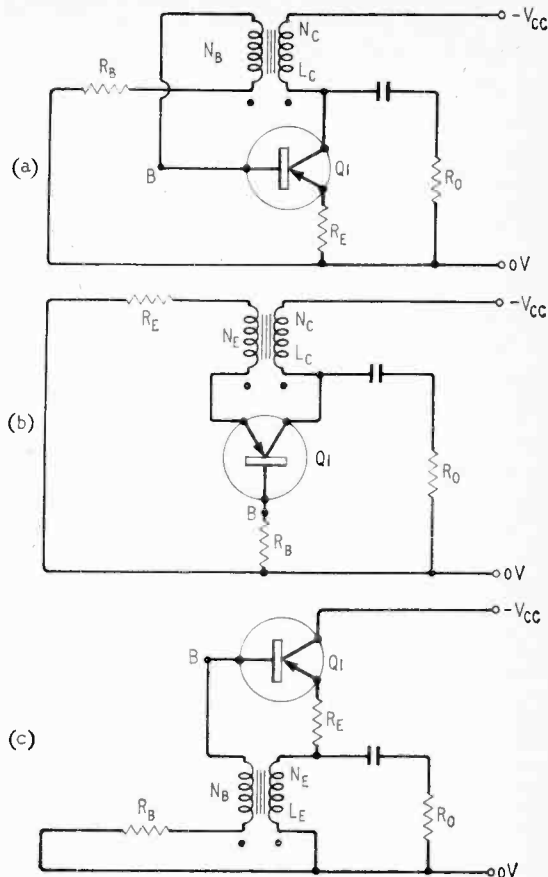

Fig. 76. Saturated monostable blocking oscillator design circuits. (a) Collector-base feedback, (b) collector-emitter feedback, (c) emitter-base feedback.

The load resistor R_O is shown capacitively coupled, but other ways of connecting the load resistance are discussed later.

When you are designing a blocking oscillator, you are aiming in the first place for a pulse of specified width, T_p , and amplitude, V_p , feeding into a load, R_O . The most important feature of the design is usually the pulse width, and this is determined primarily by the transformer characteristics.

In the collector-base feedback circuit of Fig. 76(a), if it is beta limited, the inductance of the transformer collector winding, L_C , necessary to give a pulse width T_p is given approximately by

$$L_C \text{ (beta limited)} = \frac{T_p}{\frac{N_B/N_C}{R_B + R_E} - \frac{1}{R_O}} \quad \dots (1)$$

where N_B and N_C are the number of turns in the base and collector windings of the transformer, R_B and R_E are the external base and emitter resistors, and R_O is the load resistance.

To give a pulse height, V_p , the supply rail voltage, V_{CC} , required is given by:

$$V_{CC} \text{ (beta limited)} = V_p \left(1 + \frac{R_E N_B / N_C}{R_B + R_S} \right) \quad (2)$$

These formulæ assume that a transistor with a

reasonably high beta is used—say better than about 30.

To ensure that the blocking oscillator is actually operating in the beta limiting mode, the transformer must be such that its core does not saturate under the peak magnetizing current in the windings. It can be shown that the peak magnetizing current is given approximately by:

$$I_M(\text{beta limited}) = V_P \left(\frac{N_B/N_C}{R_B + R_E} - \frac{1}{R_0} \right) \dots \dots (3)$$

Before we can use equations (1) to (3), we must select tentative design values for N_B/N_C , R_B and R_E .

The transformer turns ratio, N_B/N_C , is governed by several factors. To give enough loop gain for the circuit to block on the pulse, it can be shown that N_B/N_C must be much less than h_{FE} , the d.c. current gain of the transistor. For fast switching between on and off, values of N_B/N_C between 1/5 and 1/1 are common. As h_{FE} is usually higher than 10, a turns ratio of this order will adequately ensure blocking. An empirical value of 1/5 is commonly used by designers.

R_B and R_E are usually selected at not less than ten times the related transistor internal resistances. With typical modern transistors this leads to lower limit values of about 500 ohms for R_B and 20 ohms for R_E .

To get the design under way, you can use the values of turns ratio and external resistances outlined above. Equations (1) to (3) then give a first estimate of suitable L_C , V_{CC} and I_M . For the value of L_C thus computed, select a suitable core and number of collector winding turns, N_C . Confirm that $N_C I_M$ is well within the ampere-turns saturation limit of the core. Select a transistor with f_{co} greater than $10/T_P$, with a voltage rating greater than the computed V_{CC} , and with a base current rating of not less than I_M . Several attempts at suitable values of R_B and R_E may be necessary before satisfactory results are achieved. Finally, make up the circuit, check T_P and V_P on an oscilloscope, and marginally adjust R_B and R_E to give the exact results required. For any given transformer, quite a wide range of variations of T_P and V_P can be effected by suitably varying these two resistor values.

So far we have been dealing with the beta limited version of the circuit of Fig. 76(a). Although it does not show up in our approximate formulæ, both the pulse width and height are partially dependent on the transistor parameters in this case. Where it is desired to reduce the effect of transistor variations from the design, it is common to design for the core-saturated mode of the blocking oscillator.

For transformer core saturation operation of the circuit in Fig. 76(a), the formulæ become:

$$L_C(\text{core limiting}) = \frac{N_C V_P T_P}{H_K} \dots \dots (4)$$

where H_K = limiting coercive force of the core selected.

$$V_{CC}(\text{core limiting}) = V_P \left(1 + \frac{R_E N_B/N_C}{R_B + R_E} \right) \dots (5)$$

$$I_M(\text{core limiting}) = H_K/N_C \dots \dots (6)$$

With the same sort of cut-and-try experimentation as before, it is possible to arrive at a suitable design of the transformer for this case.

These design procedures may seem a little vague, but they are really quite practicable, and put you into

the right area of operation to make final small adjustments to get your exact pulse requirements. In practice, incidentally, you can easily tell whether a circuit is beta or core limiting. If you vary V_{CC} and find T_P also varies materially, transformer core limiting is indicated. Otherwise the circuit is beta limiting.

Saturated Blocking Oscillators with Collector-Emitter and Emitter-Base Feedback

Figs. 76(b) and 76(c) are the collector-emitter and emitter-base feedback versions of the collector-base feedback circuit discussed in Fig. 76(a). Equivalent simplified formulæ for these new versions are:

(a) Saturated, collector-emitter feedback—Fig. 76(b)

(1) Beta limited:

$$L_C = \frac{T_P}{\frac{N_E/N_C}{R_B + R_E} - \frac{1}{R_0}} \quad V_{CC} = V_P \left(1 + \frac{R_B N_E/N_C}{R_B + R_E} \right)$$

$$I_M = V_P \left(\frac{N_E/N_C}{R_B + R_E} - \frac{1}{R_0} \right)$$

(2) Core limited:

$$L_C = N_C V_P T_P / H_K \quad V_{CC} = V_P \left(1 + \frac{R_B N_E/N_C}{R_B + R_E} \right)$$

$$I_M = H_K / N_0$$

In these cases, R_B and R_E are governed by the same considerations as before, and the optimum transformer turns ratio N_E/N_0 also lies between 1/5 and 1/1.

(b) Saturated, emitter-base feedback—Fig. 76(c).

(1) Beta limited:

$$L_C = \frac{T_P}{\frac{N_B/N_E}{R_B + R_E} - \frac{1}{R_0}} \quad V_{CC} = V_P \left(1 + \frac{R_E N_B/N_E}{R_B + R_E} \right)$$

$$I_M = V_P \left(\frac{N_B/N_E}{R_B + R_E} - \frac{1}{R_0} \right)$$

(2) Core limited:

$$L_C = N_E V_P T_P / H_K \quad V_{CC} = V_P \left(1 + \frac{R_E N_B/N_E}{R_B + R_E} \right)$$

$$I_M = H_K / N_E$$

In these cases, the optimum transformer turns ratio, N_B/N_E , lies between 1.2/1 and 2/1. It is common to start with a value of 1.2/1.

Non-saturated Blocking Oscillators

Where very short pulses are required, a common circuit device is to diode-clamp the transistor so that the collector-emitter voltage during the pulse cannot fall below a certain limit. This gives rise to the family of non-saturated blocking oscillators shown in basic form in Fig. 77. The three possible feedback modes are illustrated. In all the cases of Fig. 77 the transformer turns ratio and external resistor values are set by the same considerations as apply in the saturated unclamped blocking oscillator cases discussed earlier. Those interested in this type of circuit should consult a standard treatment such

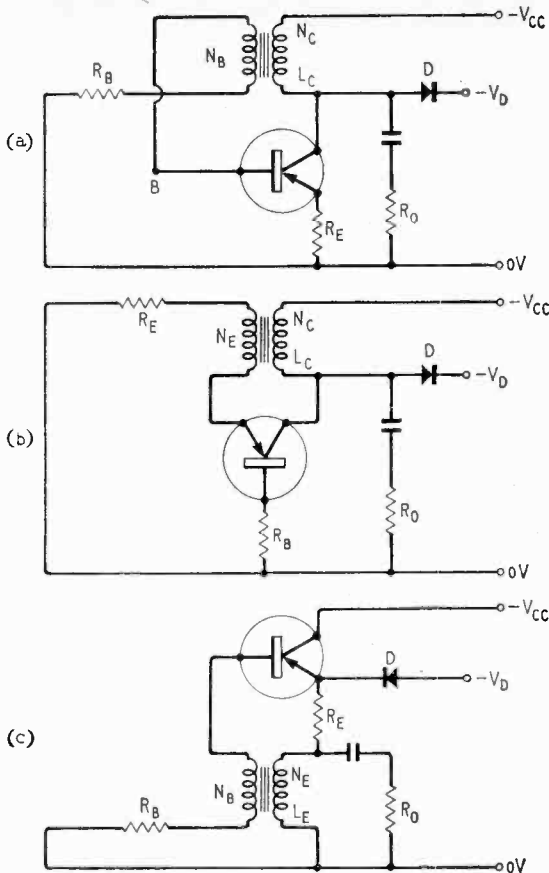

Fig. 77. Non-saturated monostable blocking oscillator circuits. (a) Collector-base feedback, (b) collector-emitter feedback, (c) emitter-base feedback.

as given in H. J. Reich "Functional Circuits and Oscillators" (Van Nostrand, 1961).

Recovery Time

It can be shown that the recovery time of a blocking oscillator is of the order of $4L/R$ where L is the inductance of the transformer primary winding and R is the resistance reflected across that winding from the load and other circuit resistances. This sets an upper limit to L for a given load resistance when a maximum pulse repetition rate is prescribed, i.e. a minimum recovery time.

Reverse Spike

The reverse spike on the back edge of the blocking oscillator pulse is basic to the circuit. In general the amplitude, shape, and width of this spike depend on the various losses and reactances in the circuit.

It can be shown that the less the reverse spike is suppressed the more rapidly does the circuit recover ready to receive the next trigger pulse. A common design approach is to fix all the various circuit parameters in such a way that the spike height is within the collector-emitter voltage rating of the transistor, but not to damp it too severely. This avoids excessively long recovery times.

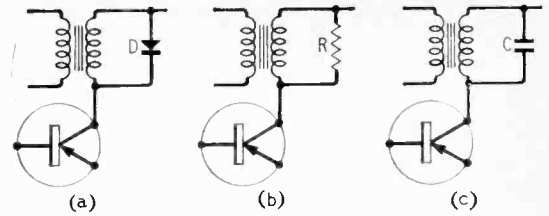

Fig. 78. Switch-off overshoot control circuits. Primary winding shunted by (a) diode, (b) resistor, (c) capacitor.

The ways commonly used to control the shape of the spike are illustrated in Fig. 78. The most usual technique is to connect a diode across one of the windings, e.g. the collector as in Fig. 78(a). This diode clamps the collector voltage to the negative supply rail on switch off and almost completely removes the overshoot spike. Often a resistance is also placed in series with this diode to reduce the diode damping. Again a resistance (which may be merely the load resistance or some other circuit damping resistance) is placed across the transformer winding and the diode dispensed with as shown in Fig. 78(b). A final method sometimes used is to shunt the collector winding with a small capacitance as in Fig. 78(c). It is emphasized that some form of damping must be used in practice, otherwise the blocking oscillator may go into oscillation or, if not, may "ring" so that the end of the pulse degenerates into a damped series of sine waves.

Astable Operation

So far we have been considering only the monostable version of the blocking oscillator where the circuit goes into a blocked pulse only when it is actively triggered by some trigger pulse input. In practice the blocking oscillator is often required in a free-running version. For this the transistor is d.c. biased so that, if the circuit were not oscillating, the transistor would be conducting. This can be achieved in several ways. In Fig. 79(a) the resistor R forward biases the transistor. When it blocks and gives out a pulse, it also discharges the capacitor C_B . At the end of the pulse C_B begins to recharge through R until once again the transistor is forward-biased and blocks once more. This circuit will then block and relax, block and relax, with a pulse repetition rate set primarily by the time constant RC_B .

An alternative biasing method is shown in Fig. 79(b) where the repetition rate controlling network, RC_B , is a parallel one. In this case the capacitor charges when the circuit blocks and then in the relaxation period discharges through R . Here once again the repetition rate is set largely by the time constant RC_B .

In Fig. 79(c) and (d), the time constant for pulse repetition is set in the emitter circuit by a series or parallel arrangement $R_E C_E$. Here again the repetition rate is proportional to the $R_E C_E$ product.

With astable circuits of this type the main problem is to provide a pulse of known width at a known and preferably variable pulse repetition rate. Unfortunately in practice it will be found that when you try to vary the pulse repetition rate by varying R you will at the same time vary the pulse width T_p . Circuits have been derived, however, where the pulse repetition

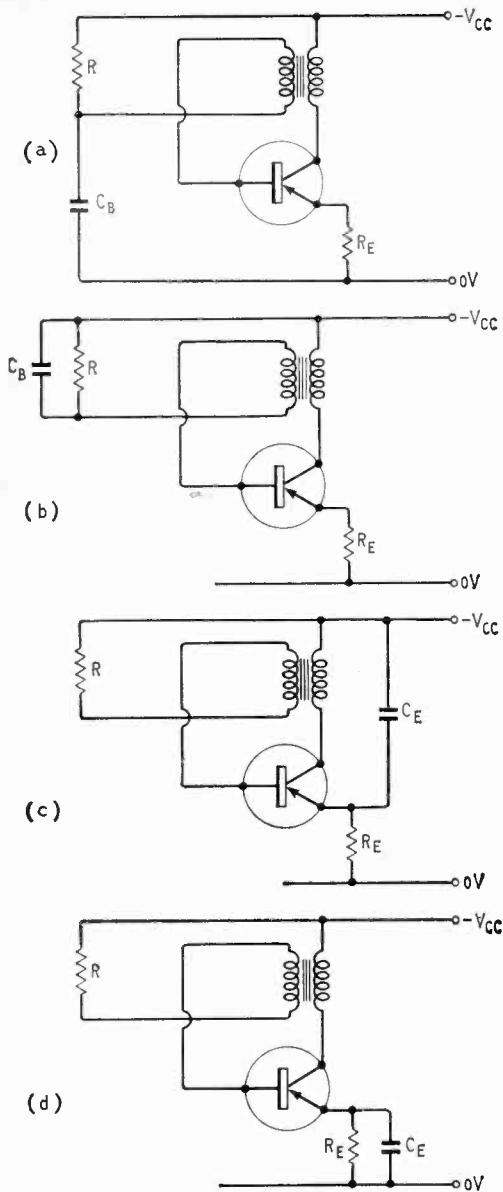

Fig. 79. A stable blocking oscillator RC bias network. (a) Base, series, (b) base, parallel, (c) emitter, series, (d) emitter, parallel.

rate can be made independent of the pulse width, e.g. Fig. 82(b).

Triggering

Where a blocking oscillator is controlled by a trigger pulse, this trigger can be applied in a variety of ways. A common one is to apply a sharp negative-going pulse to the base via an isolating capacitance such as C_T in Fig. 80(a). The capacitively coupled trigger could also be fed into the other end of the base winding, as shown dotted in the same illustration.

Although capacitor coupling of the trigger pulse is by far the commonest, in some cases the trigger

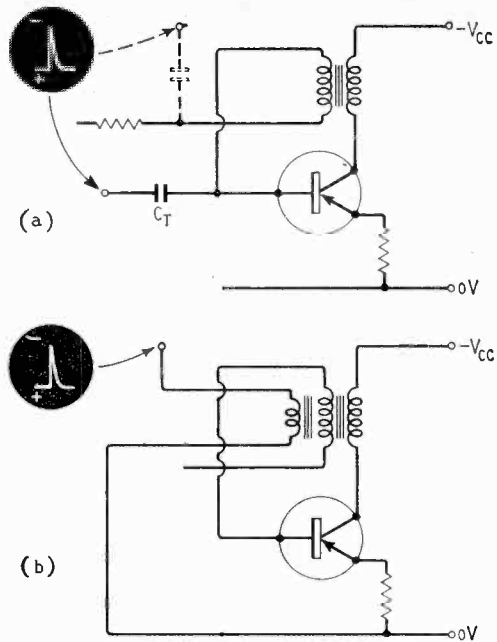

Fig. 80. Triggering circuits. (a) Via capacitor, (b) via transformer winding.

is supplied via a separate transformer winding as shown in Fig. 80(b). Obviously this method adds complexity to the transformer specification, and is normally avoided.

The requirements on the trigger pulse are not very stringent in blocking oscillators. The most obvious one of course is that the width of the trigger pulse should be less than that of the blocking oscillator output pulse, otherwise the switch-off at the end of the output pulse can be complicated. On the other hand the trigger pulse must not be too short, otherwise due to the slow switching speed in the transistor and the effect of stray circuit capacitances the switch-on action may not be firmly initiated. Here a little experimentation with the trigger shape may be necessary to arrive at an optimum trigger amplitude and width. As a rough rule of thumb, some designers aim for a trigger pulse about 20% of the minimum output pulse width.

Output Take-off

The pulse can be taken off from a blocking oscillator either directly, capacitively or inductively. In Fig. 81(a) the output load R_O is shown directly in series with the transistor. A common alternative is Fig. 81(b) where the output is taken capacitively from the transistor collector to the output load R_O , or as shown dotted in the same circuit from the emitter resistor, R_E .

A final method is shown in Fig. 81(c) where a tertiary winding in the transformer is used to couple to the load. This last method has a big advantage that the polarity of the output pulse can be selected at will.

As can be seen from the earlier analysis, the load resistance can have quite a significant effect on pulse output width and height. Where a blocking oscillator

is to be used with a variety of different loads, it is common to use a buffer emitter-follower so that the varying output loads have a relatively negligible effect on the pulse characteristics.

Applications

The primary purpose of a blocking oscillator is to generate pulses of large peak power in a train of low mean power. For example, it is possible to use an r.f. alloy transistor of 100 mA mean current rating to give a peak pulse of 2 amps. The average power dissipation is kept within the transistor mean power rating since the duty cycle is low. This property of the blocking oscillator is particularly useful for the rapid discharge of a capacitor. In this fashion the blocking oscillator is commonly used for sawtooth wave generation. A full discussion of this will be found in the chapters on line-time base and field-time base circuits in T. D. Towers' "Transistor Television Receivers," Iliffe Books Ltd., 1963.

The blocking oscillator is widely used as a very low impedance switch. Typical of this is when it is used to drive a silicon controlled rectifier, or is used as a voltage comparator switch.

One use of the blocking oscillator is as a source of pulses of defined shape. A specific case of this is where a blocking oscillator triggered from a high-

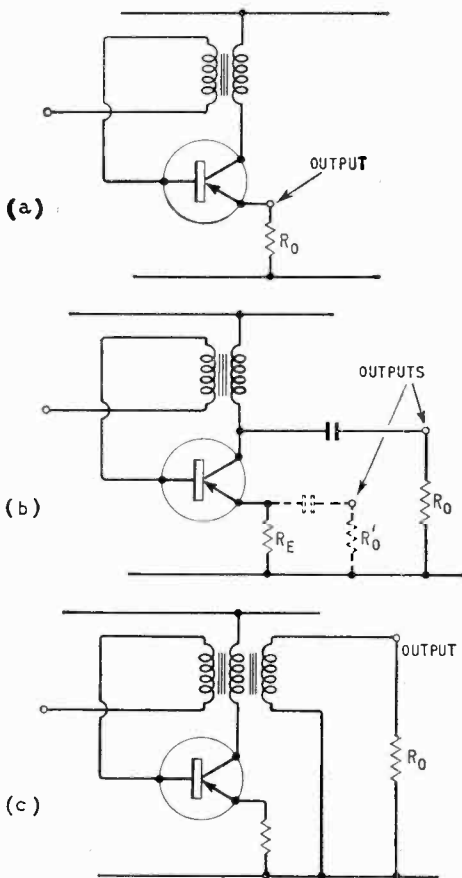

Fig. 81. Output take-off. (a) Via series resistance, (b) via capacitor, (c) via transformer winding.

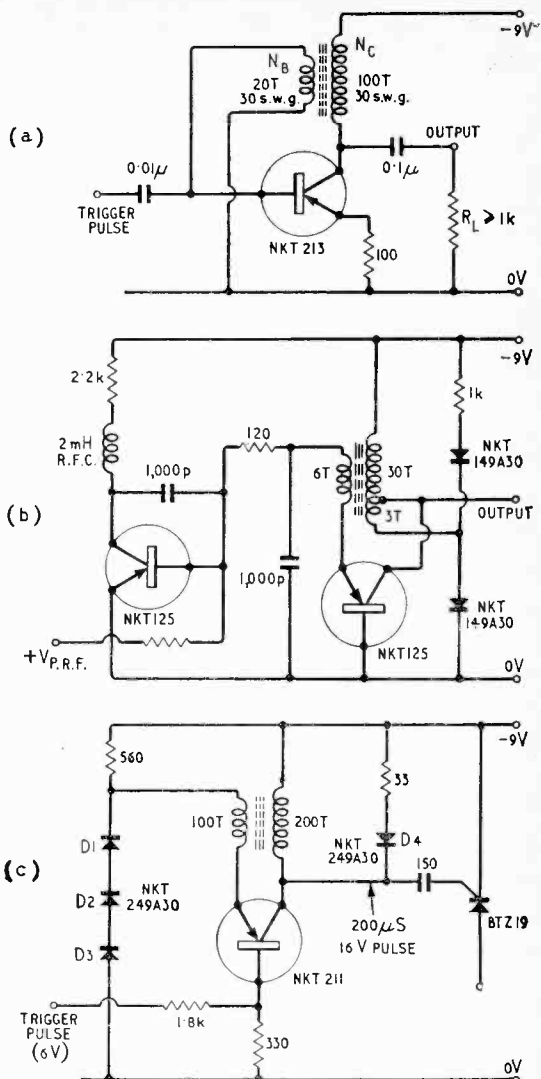

Fig. 82. Practical examples. (a) Simple 10 μ sec monostable, collector-base feedback. Transformer on LA2517 pot core. (b) 1 μ sec astable with p.r.f. variable from 50 to 250 kc/s. Transformer on FX 1011. P.r.f. 50-250 kc/s for V_{P.R.F.} = 2-12V. (c) s.c.r.-firing monostable with 200 μ sec, 16V output pulse. Transformer on FX 1238 (X2).

stability crystal oscillator is used as a clock pulse source to synchronize the various functions of a computer.

Pulse reshaping, i.e. converting ragged pulses back to a standard shape, is another common use of the blocking oscillator.

An astable blocking oscillator can be used as frequency divider by synchronizing it with an input signal of a frequency several times its own natural repetition rate. In this way it has been widely used in divider type electronic organs, where the control frequency is slightly faster than twice the natural frequency of the blocking oscillator being triggered. By this means, each of the blocking oscillators in a divider chain operates at a frequency one half of that immediately above it.

In Fig. 82 will be found three typical practical examples of blocking oscillator circuits. The circuits have been given in sufficient detail for the interested constructor to make them up.

In Fig. 82(a) is shown a simple 10 μ sec-pulse-width, monostable, collector-base feedback, saturated blocking oscillator. From the details on the circuit diagram it will be noted that a 5:1 turns ratio is used in the transformer. To show how the practical simplified formulæ do in fact work, it should be noted that this circuit was computed to work at a pulse width of approximately 11 μ sec and turned in the event to be 10 μ sec. By adjusting the slug of the ferrite core of the transformer it was possible to vary the pulse width by $\pm 5\%$ on the actual value found.

The circuit given in Fig. 82(b) is that of a μ sec astable blocking oscillator beta limited and non-saturated. The circuit is such that it is possible to vary the p.r.f. from 50 to 250 kc/s by varying the positive control voltage on the emitter of the blocking oscillator transistor and yet keep the pulse width materially constant. This is possible because of the Miller-effect 1000 pF capacitance from the collector to the base of the other transistor. The 1000 pF capacitor across the emitter of the blocking oscillator transistor is designed to sharpen the front and back edges of the pulse. The collector of the blocking oscillator transistor is diode-clamped by a three-

turn overwind on the collector winding which prevents the transistor going into bottoming. The diode and the 1 k Ω resistance in series across the total collector winding is the normal reverse spike suppression circuit. The 1 k Ω value is relatively high and places a minimum damping on the μ sec circuit to ensure that the recovery time is not degraded.

Fig. 82(c) shows the typical s.c.r. firing monostable providing a 200 μ sec, 16 V output pulse in a collector-emitter feedback, saturated transistor, arrangement. The diodes D1, D2, D3 are inserted to provide satisfactory thermal stability at high ambient temperatures up to 45°C. This circuit is suitable for driving a typical s.c.r. such as the BTZ19.

Summary

In this article on blocking oscillators I have attempted to give the reader some idea of the main factors which govern the design of the blocking oscillators and even to enable him to make up a few circuits to try his hand. In practice it will be found that if you use variable resistors for R_b and R_e, you can "wind the circuits up and down" and test out the effects of varying the controlling circuit elements. The references quoted at various points in the article should serve as a guide to those interested in a more rigorous approach to the design of blocking oscillators.

September Conferences and Shows

UNITED KINGDOM

- 3-9 Kelvin Hall, Glasgow
Scottish Industries Exhibition
 (H. Quinn, 83 Kingsway, London, W.C.2)
- 7-11 Nottingham University
Magnetism
 (Inst. Phys. & Phys. Soc., 47 Belgrave Sq., London, S.W.1)
- 7-13 Farnborough
Air Show
 (S.B.A.C., 29 King St., London, S.W.1)
- 10 Queens Hotel, Manchester
Audio Symposium
 (A.P.A.E., 394 Northolt Rd., S. Harrow, Middx.)
- 10-12 Loughborough College
Audio-Visual Teaching Aids
 (I.E.E., Savoy Pl., London, W.C.2)
- 14-18 Brighton College of Tech.
Analogue Computation Conference
 (British Computer Society, Finsbury Ct., Finsbury Pavement, London, E.C.2)
- 15-17 Hull University
Luminescence and Related Phenomena in Solids
 (Inst. Phys. & Phys. Soc., 47 Belgrave Sq., London, S.W.1)
- 23-24 St. Ermins Hotel, S.W.1
Ultrasonics Conference
 (Ultrasonics, Dorset House, Stamford St., London, S.E.1)
- 23-25 N.P.L., Teddington
Fundamental Problems of Low-Pressure Measurements
 (B. S. W. Mann, N.P.L. Standards Division, Teddington)
- 29-1 Oct. Savoy Place, W.C.2
Lasers and their Applications
 (I.E.E., Savoy Pl., London, W.C.2)
- 29-1 Oct. Hotel Russell, W.C.1
Cabinet Styling Accessories
 (R.I. Exhibitions, 59 Russell Sq., London, W.C.1)
- 29-1 Oct. Metropole, Brighton
Battery Symposium
 (F. J. L. Copping, c/o Min. of Aviation, Room 413, St. Giles Ct., St. Giles High St., London, W.C.2)

OVERSEAS

- 6-13 Leipzig
Autumn Trade Fair
 (Leipziger Messeamt, Post Box 329, Leipzig C 1)
- 7-11 Tokyo
Microwaves, Circuit Theory and Information Theory
 (Dr. Kiyoshi Morita, Institute of Electrical Communication Engineers, 2-8 Fujimicho, Chiyoda-ku, Tokyo)
- 12-20 Milan
Italian Radio, TV & Component Show
 (A.N.I.E., Via Donizetti 30, Milan)
- 14-16 Washington, D.C.
Military Electronics
 (I.E.E.E., Box A, Lenox Hill Station, New York, 21)
- 14-18 Boulder, Col.
Radio Meteorology Conference
 (J. W. Herbstreit, Central Radio Propagation Lab., N.B.S., Boulder, Colorado)
- 14-18 Pari
Microwave Tubes
 (Secretariat, Congrès Int'l Tubes Hyperfréquences, B.P. No. 20, Bagneux, Seine)
- 14-18 Amsterdam
Electronic Components Show
 (FIAREX, Minervalaan 82^{bis}, Amsterdam)
- 14-19 Stockholm
Instrumentation and Measurement
 (Soc. of Instrument Technology, 20 Peel St., London, W.8)
- 22-24 Long Island, N.Y.
Antennas and Propagation
 (I.E.E.E., Box A, Lenox Hill Station, New York, 21)
- 23-29 Amsterdam
Electronic Trade Exhibition
 (Secretariaat, Molenallee 63A, Wilp, Gelderland)
- 25-26 Montrea
Symposium on Communications
 (Dr. F. G. R. Warren, Canadian I.E.E.E., P.O. Box 802, Station B, Montreal)
- 25-10 Oct. Sydney
British Exhibition Australia
 (British Overseas Fairs, 21 Tothill St., London, S.W.1)
- 28-30 Monticello, Ill.
Circuit and System Theory
 (I.E.E.E., Box A, Lenox Hill Station, New York, 21)

MANUFACTURERS' PRODUCTS

NEW ELECTRONIC EQUIPMENT AND ACCESSORIES

Microwave Dish-aerial Mounts

THE Technical Appliance Corporation, Sherburne, New York, has announced the development of a new series of microwave-aerial mounting legs for roof installation. The legs are of galvanized steel and provide great rigidity, ease of installation and accurate alignment. Available in horizontal or tilt versions, reflectors up to 12 feet in diameter can be accommodated. Threaded adjustments on all three supports provides fine adjustment in either plane for alignment. The mounts feature ball-joint, three-point support and are adjustable up to 45° in elevation and $\pm 5^\circ$ in azimuth.

12WW 301 for further details

Line Amplifier

THE line amplifier Type EL 30 recently introduced by Elcom, Northampton, although designed mainly for use in the Elcom system of audio mixing, can be used as a line-booster amplifier, or low-gain isolation amplifier in various other systems. The unit uses transistors and requires a 12 V direct supply. Both input and output impedances are 600Ω (transformers) and the frequency response extends from 30 c/s to 25 kc/s, ± 0.5 dB. The gain is +20 dB and the noise level is quoted as -100 dB at input referred to 0.775 V. The harmonic distortion at zero level is 0.2% and at +8 dBm is 0.3%.

12WW 302 for further details

Printed-board Etchant

A NEW liquid developed by Lee-Smith Chemicals, Hatfield Road, St. Albans, possesses several advantages over existing etchants, and contains additives which control "under-cutting." The etching rate is also increased and the bath has a longer life due to incorporation of a sequestering agent. Where etching baths employing spray jets are used a considerable decrease in the incidence of blocked jets is claimed.

The new etchant is supplied in packs suitable for making up baths of 1, 5, 10 or 25 gallons, the 25-gallon pack weighing 75 lb. Each

pack contains 2 packets of chemicals and a phial of liquid.

Copper, beryllium copper, brass, aluminium and steel can all be etched. The cost per gallon varies from 13s 6d per gallon for the 1-gallon pack to 10s 3d per gallon for the 25-gallon pack.

12WW 303 for further details

High-voltage Resistors

RESISTANCE values from 0.01 to 25,000 $M\Omega$ are available in a new range of high-voltage components manufactured by Victoreen Instrument Company who are represented in the U.K. by Walmore Electronics. The maximum voltages permitted range from 3.5 to 40 kV, the power-dissipation ratings ranging from 1 to 10 W. Known as the HV series, the construction is of varnished carbon.

12WW 304 for further details

D.C. Amplifier

AMONG the features presented by the Model 6460 d.c. amplifier manufactured by the Dynamic Instrumentation Company of California, U.S.A., are fast overload recovery, 30 kc/s bandwidth, gains to 1000 and high-

input impedance. Using transistors throughout, the overload recovery is claimed to be 1 msec for 10 V input on any gain range. The input impedance is $10 M\Omega$ and the output impedance is 1Ω . The linearity is $\pm 0.02\%$ from z.f. to 100 c/s, $\pm 0.1\%$ to 1 kc/s and $\pm 1\%$ to 8 kc/s. The voltage-gain ranges are 10 to 30, 30 to 100, 100 to 300 and 300 to 1000 and the variable-gain control provides continuous adjustment over each range. The equipment may be used over a temperature range of 0 to 50°C . A built-in power supply is provided but a 105 to 130 V 60 c/s mains supply is required.

12WW 305 for further details

Gallium Arsenide Diodes

DIFFUSED gallium arsenide emission diodes from the Micro State Electronic Corporation are now available in the U.K. from Ad. Auriema, Gunnersbury Lane, London, W.3. Designated Type 7000, the components are housed in TO18 cans. When biased in the forward direction the infra-red radiation is emitted in a narrow spectral band centred at approximately 0.9 microns. They are capable of 100% modulation at fre-

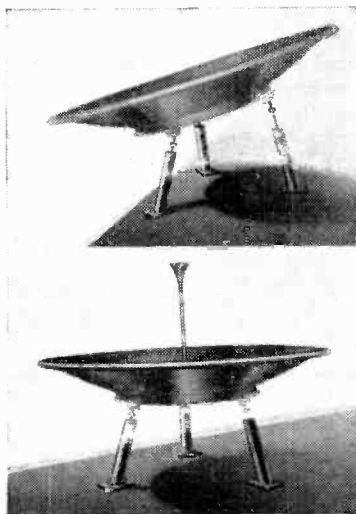

Taco microwave-aerial roof mounts.

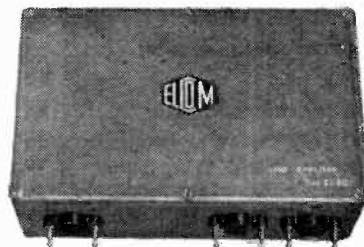

Line amplifier Type EL30 manufactured by Elcom.



Victoreen $210 M\Omega$ resistor from the HV series.



Model 6460 amplifier manufactured by Dynamics Instrumentation Company.



MS7000 gallium arsenide diode available in the U.K. from Ad. Auriema.

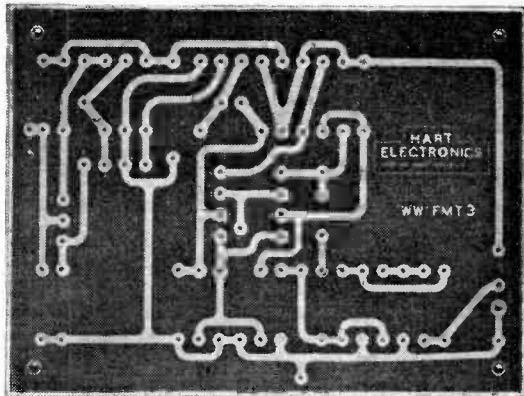

Printed-circuit pulse panel for Wireless World F.M. Tuner.

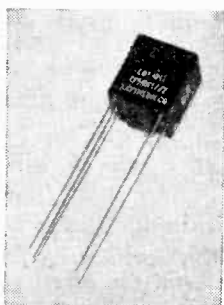

Transformer from the Raytheon Series 7600 range.

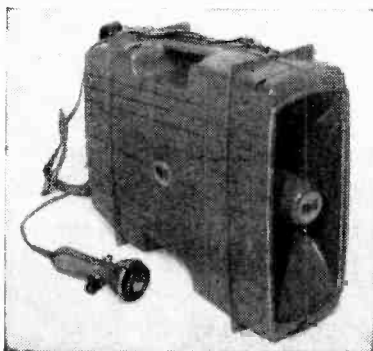

Bouyer portable p.a. equipment.

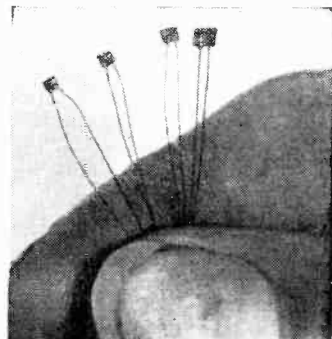

Gulton interchangeable thermistors.

quencies in excess of 100 Mc/s. Emission begins at 15 mA forward current and approximately 1.3 V. Cooling the device to the temperature of liquid nitrogen increases the emission efficiency by a factor of about 25.

12WW 306 for further details

Printed-circuit Boards

FOLLOWING the publication of the *Wireless World* F.M. Tuner, J. W. Wells (Metals), Halco House, Fallowfield, Manchester, have designed and produced printed-circuit boards for the pulse panels and i.f. amplifier.

12WW 307 for further details

Miniature Transformers

DESIGNED mainly for printed circuit use, a new range of sub-miniature audio transformers are being manufactured by Raytheon. Components from this new Series 7600 meet a wide range of requirements with impedances ranging from much less than 1 Ω to many megohms. The

frequency range which the components cater for extends from 100 c/s to 500 kc/s and the power-handling capabilities extend from 50 mW to 1.0 W. The transformers measure 0.410 \times 0.31 in across the base and are 0.47 in high. Slip-on shields are available. European, including the British Isles, sales are from Raytheon-Elsi, S.p.A., Palermo, Italy.

12WW 308 for further details

Thermistors

THERMISTORS recently introduced by Gulton are available in 5 resistance values (at 25°C). These are 1, 2, 3, 4 and 5 k Ω and they will track a specified resistance/temperature characteristic to such a tight tolerance over the temperature range -55 to 150°C that similar types may be interchanged during servicing without the calibration of the equipment being affected. Being only 0.1 \times 0.1 \times 0.05 in in size, they have a rapid response time. The maximum deviation from the specified resistance

between 0°C and 100°C is 1% and between -50°C and 150°C, 3.3%.
12WW 309 for further details

Portable Public-address Equipment

MANY unusual features are presented by the Super-Megaflex, portable public-address equipment manufactured by Bouyer who are represented in the U.K. by Douglas A. Lyons and Associates, 32, Grenville Court, Dulwich, London, S.E.19. Using semiconductors the equipment is powered by 9 U2-type batteries which are contained in the equipment. The casing is moulded in tough plastic and the loudspeaker is a high-efficiency, pressure-drive horn type. The microphone incorporates the volume control and on/off switch. Stowage space for the microphone is provided in the main body of the equipment and carrying strap and car-mounting accessories are provided. The weight of the equipment, including microphone and batteries, is 10 lb. Provision is

made for connection of a second loudspeaker.

12WW 310 for further details

Frequency Standard

A THERMOSTATICALLY CONTROLLED time and frequency standard with a basic accuracy of $\frac{1}{1000}$ sec in 24 hours is available from D. A. Pitman, Weybridge, who represent the Swiss manufacturers Voumard. The equipment has a 12-hr clock face on its front panel and number of standard frequency outputs are available. The outputs are 100 c/s, 1, 10 and 100 kc/s and 1 Mc/s. The equipment is powered by a mains supply but a re-chargeable battery is incorporated to maintain the standard during power failures. The cost is £475.

12WW 311 for further details

Subminiature Reed Switch

A SUBMINIATURE magnetic reed switch, the Hamlin MSRS-2, designed specifically for low-level logic switching is now available from Flight Refuelling, Wimborne, Dorset. Features of these new components include the use of a new silver alloy which gives a uniform contact resistance throughout the life of the relay and a high drop-out to pull-in ratio. The maximum contact resistance is 150 mΩ after 10 M operations. The switch is rated at 0.5 W the maximum current (d.c.) being 10 mA. The overall length (including leads) is 2.25 in, the length of the switch body 0.80 in and the diameter of the glass envelope is 0.09 in.

12WW 312 for further details

Portable V.H.F. Transceiver

WHERE communication between dispersed personnel is required, the Amplivox (Wembley, Middlesex) "Telex" v.h.f. transceiver may

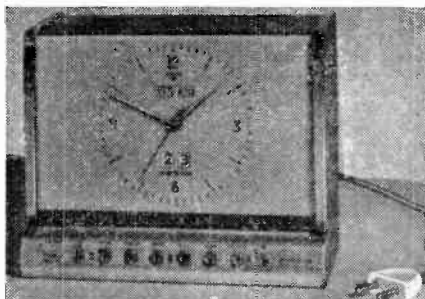

Isatome time and frequency standard manufactured by the Swiss company Voumard.

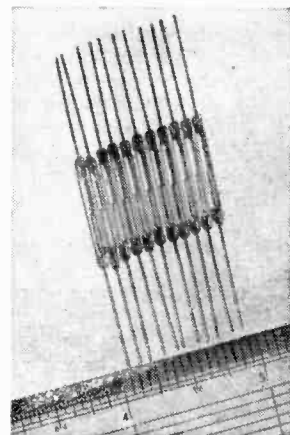

Hamlin subminiature reed switches.

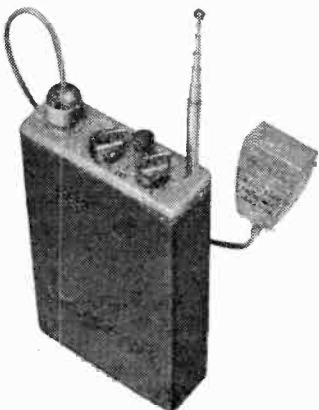

Portable v.h.f. transceiver (Amplivox).



Paco sweep generator and marker unit.

find many applications. Pocket-sized, the equipment is battery powered and up to 4 crystal-controlled channels can be provided. The battery compartment fits on to the base of the equipment, but this can be replaced by a connecting unit which permits the apparatus to be powered by a separate power supply. A telescopic aerial is provided, but provision is also made for the use of an external aerial. An in-

ternal microphone/loudspeaker is incorporated, but again a switch permits the use of a hand-held microphone/speaker unit. Accessories include a high-quality leather case, crystals, range of microphones and headsets.

12WW 313 for further details

Sweep Generator

THE Paco G.32 sweep generator and marker adder is a frequency-modulated signal generator with a centre frequency range of 3 to 213 Mc/s in 5 overlapping bands. The sweep width is adjustable from 0 to 30 Mc/s on the highest range. The markers may be added after the signal has been applied to the component under test. Obtainable from KLB Electric, Croydon, Surrey, the instrument costs £52 9s in kit form or £55 12s assembled.

12WW 314 for further details

Neon Indicators

TWO new indicator lights are announced by the Carr Fastener

INFORMATION SERVICE FOR PROFESSIONAL READERS

To expedite requests for further information on products appearing in the editorial and advertisement pages of *Wireless World* each month, a sheet of reader service cards is included in this issue. The cards will be found between advertisement pages 16 and 19.

We invite readers to make use of these cards for all inquiries dealing with specific products. Many editorial items and all advertisements are coded with a number, prefixed by 12WW, and it is then necessary only to enter the number(s) on the card.

Readers will appreciate the advantage of being able to fold out the sheet of cards, enabling them to make entries while studying the editorial and advertisement pages.

Postage is free in the U.K., but cards must be stamped if posted overseas. This service will enable professional readers to obtain the additional information they require quickly and easily.

Company. One of the indicators is a circular bright-neon type with a fluted "top-hat" shaped lens. The striking voltage is 80 to 100 V but the component is manufactured for 250 V applications. A nylon moulding is employed and the blade-shaped terminals can be used with "Lucar" quick-release connectors. The light can be supplied in red, amber and green with or without the chrome-plated brass bezel. The hole required for mounting the neon is 0.531 in.

The other lamp is a nylon-moulded, snap-in indicator which uses a high-brightness neon similar electrically to the other type. It can be supplied with two types of lens and snaps into a 0.5-in diameter hole. The lenses available are either smooth or faceted and can be supplied in red, amber and green.

12WW 315 for further details

Transistor Camera

A TELEVISION camera using transistors is announced by A.I.D.S. Ltd., Sheen Road, Richmond, Surrey. Designed around a 1-in vidicon, the equipment is available for continuous use between temperatures of -5 to $+45^{\circ}\text{C}$. Normally designed for 625-line operation, other line standards can be supplied. The camera is available (with power supply) for £200, but another power supply is available

at an extra cost which provides greater flexibility. The dimensions of the equipment are $6 \times 6\frac{1}{2} \times 10$ in and the weight 8 lb. The bandwidth is 10 Mc/s (-3 dB).

12WW 316 for further details

Varactor Diodes

A WIDE range of characteristics are offered to the designer by a series of silicon epitaxial varactor diodes manufactured by Solitron Devices and available from Auto-Electronics, Peel Grove, London, E.2. Q values up to 200, capacitances from 6.5 to 500 pF, working voltages from 15 to 200 V and power ratings from 0.5 to 2.0 W characterize the components offered in the new range.

12WW 317 for further details

Bench Magnifier

IN these days of miniaturization, bench viewers are becoming more necessary. The Sterescope Two-Ten manufactured by Vision Engineering, Woking, Surrey, provides three degrees of magnification, these being $\times 2$, $\times 5$ and $\times 10$. To obtain the maximum power a supplementary lens is rotated into position. The instrument is mounted on a universal stand which is adjustable for varying heights of operators. Illumination is provided by two

fluorescent tubes. The instrument complete with stand, lenses and tubes costs £49 10s (including £2 postage and packing).

12WW 318 for further details

Potentiometric Amplifier

THE Type A6 potentiometric amplifier which is a mains-operated instrument using semiconductor chopper circuitry is announced by Fenlow Electronics. The feedback method used produces a very high input impedance thus obviating loading effects on the source. Bandwidth up to 20 kc/s with gains from 300 to 3,000 can be provided. The drift is claimed to be less than $2 \mu\text{V}$ and the noise is less than $10 \mu\text{V}$. The output available is ± 30 volts at 50 mA. Rack-mounted and bench versions are available. Provision is made for two amplifiers to be connected to work differentially.

12WW 319 for further details

New-grade P.T.F.E.

A NEW grade of p.t.f.e. is available from Crane Packing, Slough. The gradings relate not to quality but to the properties and characteristics. This new grade is a stable form of the compound having fine grain size and a high tensile strength relative to the basic form material. Some comparative figures are given between this new grade and the basic form. The ultimate tensile strength is given as 4,000 lb/sq in (Grade 14) and 2,000 lb/sq in (basic form), the elongation being 300% in both cases. The length stability is $\pm 0.1\%$ (g.14) as opposed to $\pm 5\%$ (basic). The diameter stability is $\pm 0.1\%$, that

(Continued on page 475)

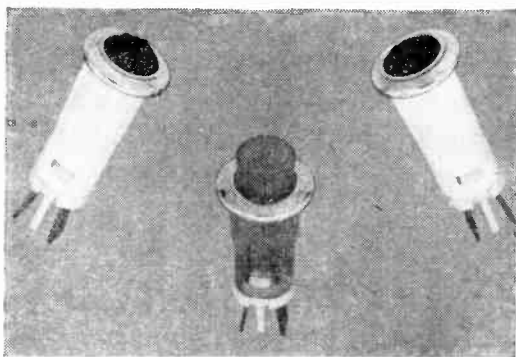

Three neon indicators from the range manufactured by Carr Fastener Company.

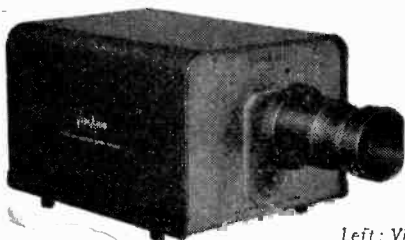

Left: Vidi Aids television camera.

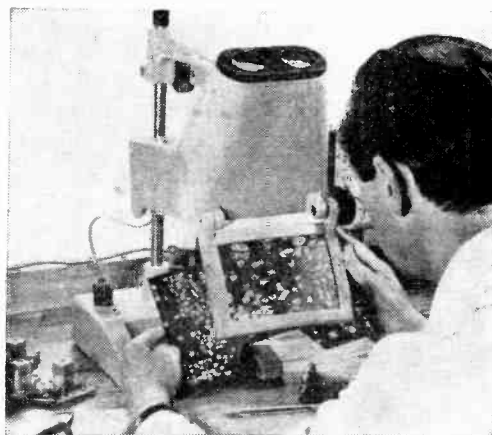

Vision Engineering bench magnifier.

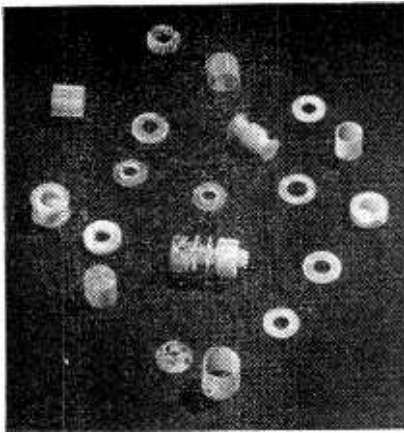

Small components of thin section manufactured from Crane Grade 14 p.t.f.e. material.

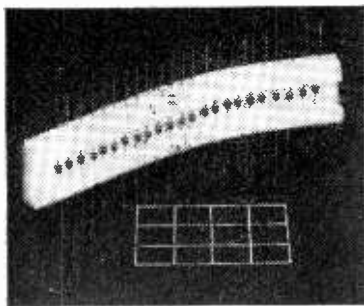

Tunnel diodes from the IN251 range produced by International General Electric Corporation.

of the basic form being $\pm 3\%$. The material can be supplied as solid rod or as components of "light section."
12WW 320 for further details

Tunnel-diode Amplifiers and Oscillators

A RANGE of low-noise, tunnel-diode amplifiers are available from Microwave Associates, Luton, Bedfordshire. Designed for radar and communication receivers in the frequency range 2 to 10 Gc/s, these amplifiers offer substantial noise-figure improvement over conventional receivers, thus extending the range of the system or permitting the use of lower power transmitters.

At C- and X-band, coaxial and waveguide models are available in "in-line" or other configurations. Complete solid-state receiver "front-ends" (including tunnel-diode mixer and i.f. amplifier) have been developed for C-band, satellite-communication systems.

Compact tunnel-diode oscillators giving outputs to the order of 50 to 100 μ W are also available. The units require a d.c. power supply of 1.5 to

Below: Programme Board constructed from Sealectro Proto-Kit.

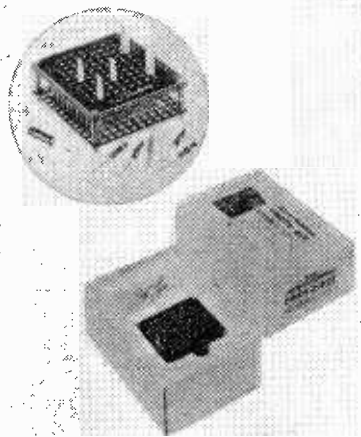

3 V. Fixed-frequency units or manually-tuned types can be frequency modulated by coupling the modulating signal to the d.c. power-supply lead. Pulse modulation can also be achieved. The specification of a typical X-band oscillator from the series is, frequency range 9.2 to 9.5 Gc/s, power output 50 to 60 μ W and bias voltage 1.35 to 1.9 V (d.c.). The oscillators can be operated over a temperature range of -40 to $+70^\circ\text{C}$.
12WW 321 for further details

Tunnel Diodes

NEW miniature tunnel diodes Series IN251 are available which cover the peak-point current range 2.2 mA to 100 mA with typical rise-times from as low as 22×10^{-12} sec. An epoxy-coated construction is said to keep the series inductance as low as 1.5 mH. Manufactured by International General Electric of New York, the diodes are available in the U.K. from Jermyn Industries, Sevenoaks, Kent.

12WW 322 for further details

"Mixing" Board

A MINIATURE programme-board device, based on Sealectroboard, that can be used for switching multiple inputs to multiple outputs is available from Sealectro, Walton-on-Thames, Surrey. The kit is available in a 10×10 -hole matrix and paralleling of inputs and/or outputs may be achieved by simply inserting a connecting pin at the desired points in the matrix. It is

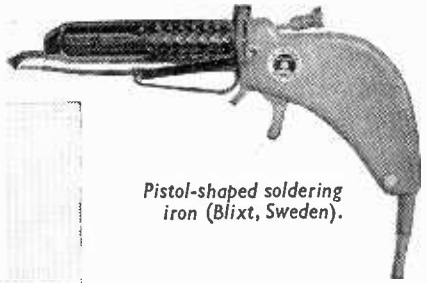

Pistol-shaped soldering iron (Blixt, Sweden).



Liquid-electrolyte tantalum capacitors (Plessey-U.K.).

envisaged that the boards will be used in audioequipment demonstrations for providing a simple, but efficient, means of combining various amplifiers and loudspeakers.

12WW 323 for further details

Soldering Iron

THE Blixt soldering iron, which enables one-hand soldering, can now be obtained in the U.K. from Oliver Dow, Finchley, London. Sixteen feet of flux-cored solder can be loaded into the handle of the soldering iron which is pistol shaped. The solder is fed to the bit by depressing and releasing the trigger. The iron is supplied with a spare bit and the cost is approximately £5.

12WW 324 for further details

Tantalum Capacitor

A NEW range of liquid-electrolyte, tantalum capacitors, with working voltages up to 75 V, is available from the Dielectric and Magnetic Division of Plessey-U.K. (Towcester). Known as Type AHS, the components are extremely stable. The capacitors are obtainable between 33 and 470 μ F and can be used in temperatures of up to 150°C . The leakage current is less than $2 \mu\text{A}$.

12WW 325 for further details

Correction

THE Belling-Lee fuseholder described on p. 388 of the previous issue takes fuses $\frac{3}{16}$ in in diameter and not $3\frac{3}{16}$ in as stated.

NEWS

FROM

INDUSTRY

Group profit of **Cable and Wireless Ltd.** for the year ended 31st March, at £3,362,934 shows a drop of £767,744 on the 1962/63 result. Group profit after taxation of £1,300,879 (£1,500,222) and other deductions amounted to £2,062,055 and represents a drop of nearly £600,000 on the previous year's result.

British Relay Wireless and Television Ltd. announces a trading profit of £4,732,364 for the year ended 25th April. This represents an increase of £126,641 on the 1962/63 result. Attributable profits for the year, after deductions—including a modest £3,233 (£3,646) for tax and £3,714,339 (£3,696,884) for depreciation—amounted to £849,172 (£687,900). British Relay also announces that its subsidiary company **Pay-TV Ltd.**, formed to promote subscription television, has now been re-constituted with **Associated British Picture Corporation Ltd.**, **British Home Entertainment Ltd.** and **British Relay Wireless and Television Ltd.** as equal shareholders. The offices of **Pay-TV Ltd.**, for the time being, will be at **Royalty House, 72 Dean Street, London, W.1.**



The **British Overseas Airways Corporation** is to use five **Elliott** procedural trainers to aid instruction of flight crews and maintenance staff of the new **Vickers VC 10** jet airliners which are now going into service. The trainers, which have been developed and engineered to **B.O.A.C.** requirements by the trainer and simulator division of **Elliott-Automation**, comprise two **Elliott** visual display trainers (one covering the electrical system and the other covering the fuel management system), a radio aids trainer, a flight systems trainer, and an airframe, engine and electrical systems trainer. The main operational radio and radar equipment of the **VC 10** is fitted to the radio aids trainer along with an instructor's panel, which carries controls for demonstrating the various systems and providing synthetic signals. A list of this equipment appeared on page 370 of the July issue.

Thorn Electrical Industries Ltd. group trading profit for the year ended 31st March, amounted to £10,551,798 and shows an increase of over £4.5M on the previous year's result. Tax this year took £2,976,920 as against £1,371,848 in 1962/63 and after all deductions, including depreciation of £2,004,354 (£1,498,543), the net profit amounted to £4,549,624, and shows an increase of £1,664,779.

Metal Industries.—After an excellent recovery in the second half of the year, **Metal Industries** group trading profit for the financial year, ended 31st March, totalled £1,606,516. This still represents a drop of over £800,000 on the previous year's result. Tax took £782,960 (£1,229,839) leaving, after other deductions, a net profit of £823,556 as against £1,231,103 in 1962/63.

Royston Industries group pre-tax profits for the year ended 31st March amounted to £271,271 as against £174,316 in 1962/63. After providing £68,242 for taxation (£31,146), £20,000 for tax equalization and making other deductions, net profit for the year amounted to £183,029. This shows an increase of £40,000 on the previous year's result.

Concord Electronics.—Agreements have recently been concluded between the **M.E.L. Equipment Company** and **Télécommunications Radioélectriques et Téléphoniques**. The agreements cover technical and commercial co-operation, and have been drawn up with the object of offering a combined source of supply of equipment for the **Concord** supersonic airliner programme. Each company is capable of producing in its factories equipment developed by either company.

A new £25,000 demonstration microwave link is being built in Kent by **Standard Telephones and Cables Ltd.** to help boost its export business in this type of equipment. Since a true long-distance link would be impracticable for demonstration purposes, this link is being built to simulate one of about 175 miles long (the international reference distance for measuring the performance of microwave systems) by sending the radio signals back and forth for a total of six transits. Each transit will simulate a station-to-station hop of about thirty miles. Two sets of aerials are to be used, and frequency and polarization will be changed on each hop. The pair of aerials shown are built in the grounds of **S.T.C.'s** factory at **Footscray**.

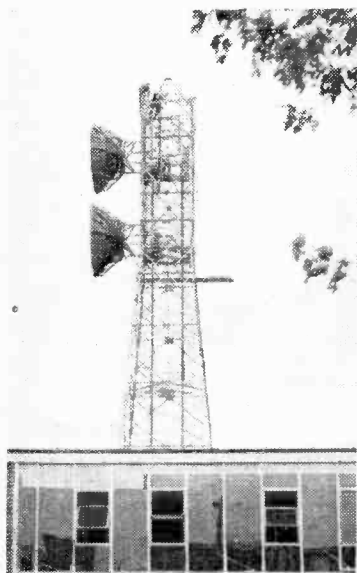

Printed Circuits.—G.E.C. (Electronics) Ltd. announces the launching of a comprehensive service for the design and manufacture of printed circuits. All printed circuits made by G.E.C. Electronics are produced by the photographic etched foil technique in its printed circuit division which is based at Spon Street, Coventry. As part of the service, an advisory unit has been set up and will be freely available at all stages of development and manufacture on problems of design, materials and technique.

A new company under the name **Pandect Precision Components Ltd.** has been formed to offer specialized design and manufacture service to companies and individuals requiring non-standard wire-wound devices and test equipment. This company, which is a subsidiary of Pandect Instrument Laboratories Ltd., operates from Wellington Road, High Wycombe, Bucks. (Tel.: High Wycombe 2150.)

The Analex Corporation, of Boston, Massachusetts, has formed a wholly owned British subsidiary to handle sales and service of its electronic data processing equipment. Known as Analex Ltd., it will operate from Remead House, Uxbridge, Hillingdon, Middx. (Tel.: HAYes 8734.)

British Communications Corporation Ltd., a subsidiary of Controls and Communications Ltd., has signed an agreement with the **R.F. Communications Inc.**, of New York, for the manufacturing rights in the United Kingdom of its single sideband equipment.

Impectron Ltd., of 125 Gunnersbury Lane, London, W.3, announces that it has received a number of new U.K. agency rights for overseas companies. Included in the list are the following Japanese organizations: Shizuki, whose products include film and electrolytic capacitors; Pioneer, who make all types of loudspeakers; Alps, capacitor and potentiometer manufacturers; Soshin, makers of mica and ceramic capacitors and associated components; and Unicorn, who make ceramic disc and polystyrene capacitors.

Sylvania.—The agency in the United Kingdom for electronic components distributed by the Sylvania International Division of General Telephone and Electronics International S.A., of Geneva, has been transferred from Thorn Electronics Ltd. to Thorn-AEI Radio Valves and Tubes Ltd., 155 Charing Cross Road, London, W.C.2. (Tel.: GERrard 9797.)

(Continued on page 478)

WIRELESS WORLD, SEPTEMBER 1964



THE HOUSE OF BULGIN AT YOUR SERVICE

LIST NO. P.360/SE

A pair of 3-pole highly polished phenolic connectors consisting of **List No. P.429 panel-mounting Plug**, and **List No. P.430/SE Socket**, the latter being the mains-lead member, capable of accepting 7/36g. or 14/36g. flex. Fully polarised and non-reversible, carrying 250V., 1.5A., A.C. or D.C. Protection against accidental contact can be provided by a flexible plastic cover (**Part No. 9455**) which surrounds the terminals and cable connections of the apparatus-Plug. This cover can also transform the Plug into a safe, non-mounting member for additional uses.

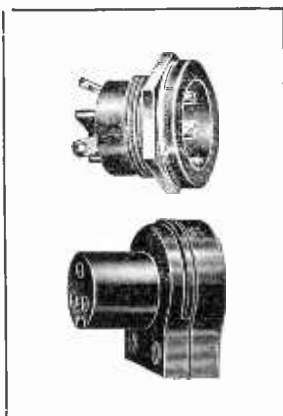

LIST NO. P.73

S.A.1861 Plug and **S.A.1862 Socket** combine to make this well-known 3-pole mains Inlet Connector. Slit plug-pins entering into solid tubular sockets ensure excellent electrical and mechanical "fit," a popular pair for a wide variety of professional and domestic uses. Highest commercial grades of phenolic material go into the moulding of these connectors, the standard colour being black. The plug is available with 6 BA pinch screws terminals, or alternatively with soldering-tags. Socket cable entry is axial, and terminals and all metal parts are nickel-plated. Up to 5A., at 250V., A.C.

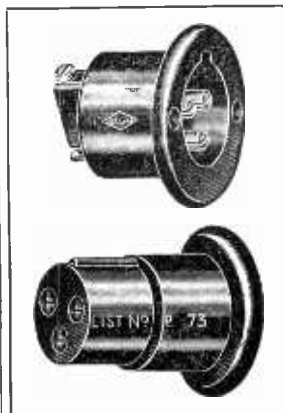

LIST NO. P.493

This model is a P.O. standard to which P.O. numbering can be affixed upon request it is also accepted by H.M. Elec. Inspector of Factories. The **S.A.2096 Plug** is equipped with solid pins and the **S.A.2097 Socket** has protected resilient sockets; neither of the two members will cross-mate into members of other pairs. Moulded in high-grade phenolic, the connectors carry 1A., at 500V., A.C. Standard colour is black with Side-entry for Cable and Approved Cable-grip. A supplementary device is available, to position between the plug-flange and the panel, to provide a lock against accidental de-mating. (Order as: **P.493/Clip Retainer**.)

Comprehensive Leaflet Available. Quote Ref. 1506/C.



MANUFACTURERS AND SUPPLIERS OF RADIO
AND ELECTRONIC COMPONENTS TO

ADMIRALTY	MINISTRY OF WORKS	B.C.C.
WAR OFFICE	MINISTRY OF AVIATION	G.P.O.
AIR MINISTRY	MINISTRY OF SUPPLY	I.T.A.
HOME OFFICE	RESEARCH ESTABLISHMENTS	M.S.L.
CROWN AGENTS	U.K.A.R.	D.S.R.

A. F. BULGIN & CO. LTD.
Bye Pass Rd., Barking, Essex.
Tel: RIPPleway 5588 (12 lines)

12WW-109 FOR FURTHER DETAILS.

Anglo-American Computer Agreement.—Negotiations have recently been completed between Associated Electrical Industries Ltd. and the General Electric Company of America to enable all current and future G.E. designs of process computers, associated peripheral equipment and programming information to be used in the United Kingdom by A.E.I. One of the first G.E. computers to be built by A.E.I. is the GE/PAC 4000. This will be added to the existing range of computers manufactured within the A.E.I. Electronics Group, and will be sold in the United Kingdom and overseas by its member company A.E.I. Automation Ltd.

"Elettra".—The Marconi International Marine Company, will in future use the trade name "Elettra" for all its sound systems installations, whether ashore or afloat.

The **Electro-Tec Corporation**, of New Jersey, U.S.A., has signed an agreement with Standard Telephones and Cables Ltd., granting sole rights for the exploitation of "Wedge-Action" and other Electro-Tec relays in the United Kingdom and continental Europe. The U.K. outlet is the electromechanical division of S.T.C. at Harlow, Essex. European sales are to be made through I.T.T.-Standard, Brussels, and the various I.T.T. companies based in Europe.

Decca Radar's latest factories and laboratories, which have been built at Cowes in the Isle of Wight, were officially opened in July. This unit of the Decca organization will take over the development and production of nearly all of the larger radar systems the Company manufactures, including air surveillance radars, defence equipment for early warning and meteorological radars. Nearly six hundred are employed at Cowes.

Home Office Contract.—An order for 450 motor-cycle four-channel amplitude modulated v.h.f. transceivers for use by the British Police Forces has been received by the telecommunications division of Ultra Electronics Ltd. This follows the successful introduction of the Ultra 4A5 motor-cycle set last year. An initial order has also been received from the Metropolitan Police for twenty-six of their Type 4B6 frequency modulated transceivers.

The radio and electrical division of St. Aldate Warehouse Ltd., of Innsworth Lane, Gloucester, a member of the Debenham Group of Companies, has signed an agreement with the **Sony Corporation**, of Japan, for exclusive distribution rights in the United Kingdom of Sony domestic radio and audio products. This becomes effective on 1st September, when the previous agency, with Tellux Ltd., expires.

Telex-Southern Ltd. has changed its name to **J.A.C. Electronics Ltd.** This is as a result of Southern Instruments Ltd., acquiring the full share capital of this company, which was previously jointly owned by themselves and Telemechanics Ltd. J.A.C. Electronics Ltd. has recently moved into a new factory at 4 Station Estate, Blackwater, Camberley, Surrey. (Tel.: Camberley 5399.) The main product line of frequency measuring equipment is being continued.

Polaris Simulators.—Through its subsidiary company EMIHUS Ltd., EMI Electronics Ltd. and the Hughes Aircraft Company are providing weapon control simulators for the Royal Navy Polaris School now under construction at Faslane in Scotland.

Hoelzemann Diodes.—The Danish organization Danavox International A/S has acquired the diode manufacturing company and plant of Hoelzemann of West Germany. The entire Hoelzemann production unit has now been shipped to the Danavox factory in Copenhagen and production has started. These diodes will shortly be available through the British subsidiary, Danavox (Great Britain) Ltd., Lloyds Bank Chambers, 125 Oxford Street, London, W.1. (Tel.: REGent 7486.)

Ross Valiant, the first of ten so-called "all-freeze" trawlers which will be joining the fishing fleets of the Ross

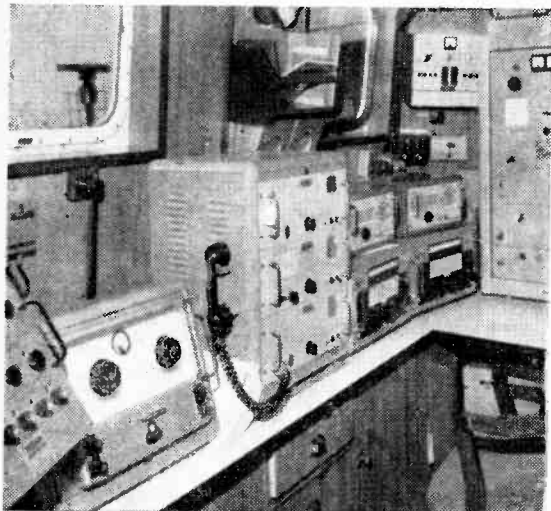

The chartroom and the wireless room (inset above) are positioned, to port and starboard respectively, on the wings of the wheelhouse which is topped by a navigating bridge.

Group, is now ready to enter service. The navigation equipment consists of an A.E.I. Type 651 high power (20kW) transistorized radar with a nine-inch display, a Kelvin Hughes Type 14/9 radar, Sperry Gyroscopes to stabilize the above, Redifon Type 262a Loran unit, Marconi "Lodestar" automatic direction finder, Kelvin Hughes Sal-64 Log, and two Decca "Simrad" Echometers. Incidentally, the A.E.I. radar equipment fitted to this vessel is the first of its type off the production line and one of the Simrad Echometers is the 10,000th unit of its type to be manufactured. The communication equipment comprises one Marconi "Globespan" transmitter, two "Atlanta" receivers and a "Kestrell" emergency transceiver, a Cossor Type CC40/91 v.h.f. transceiver, and two Hudson Type AF102 v.h.f. receivers.

